

*Линейка кондиционеров Mitsubishi Heavy на  
сезон 2002 года.*

2. Инверторные бытовые мульти-системы.  
INVERTER MULTI-SPLIT SYSTEM ROOM AIR CONDITIONER

тепло/холод

только охлаждение

Наружные блоки

SCM 45 ZA

SCM 45 YA

SCM 68 ZA

SCM 68 YA

SCM 80 ZA

Внутренние настенные блоки

SKM 22 ZA

SKM 22 YA

SKM 25 ZA

SKM 25 YA

SKM 28 ZA

SKM 32 ZA

SKM 40 ZA

SKM 40 YA

SKM 50 ZA

Внутренний канальный блок

SRRM 40 ZA

---

Указанные модели поставляются на фреоне R22. Возможна поставка на фреоне R407.

Информацию по моделям на R407, а также старым моделям Вы можете получить в компании Бьюфорт по тел. (095) 755-84-33.

# GENERAL INFORMATION

## Specific features

- (1) **The long piping makes the location of the inside and units flexible.**
  - No need for additional charge of refrigerant : 40 m
  - Maximum piping length : 60 m
- (2) **Connectable indoor capacity**
  - Number of connectable units : 3 to 4 units
  - Total of indoor units (class kW) : 12 kW
- (3) **Indoor units are available with 6 capacities, in 2 types and 7 models.**
  - 5 capacities ..... 22, 25, 28, 32, 40, 50
  - 2 types ..... Wall mounted type (SKM), Ceiling recessed type (SRRM)
- (4) **Inverter (Frequency converter) for multi-steps power control**
  - Heating / Cooling  
The rotational speed of a compressor is changed in step in relation to varying load, to interlock with the indoor and outdoor unit fans controlled to changes in frequency, thus controlling the power.
  - Allowing quick heating/cooling operation during start-up period. Constant room temperature by fine-tuned control after the unit has stabilized.
- (5) **Fuzzy control**

Fuzzy control calculates the amount of variation in the difference between the suction air temperature and the setting temperature in compliance with the fuzzy rules in order to control the air capacity and the inverter frequency.
- (6) **Self diagnosis function**

We are constantly trying to do better service to our customers by installing such judges that show abnormality of operation as follows.

## How to read the model name

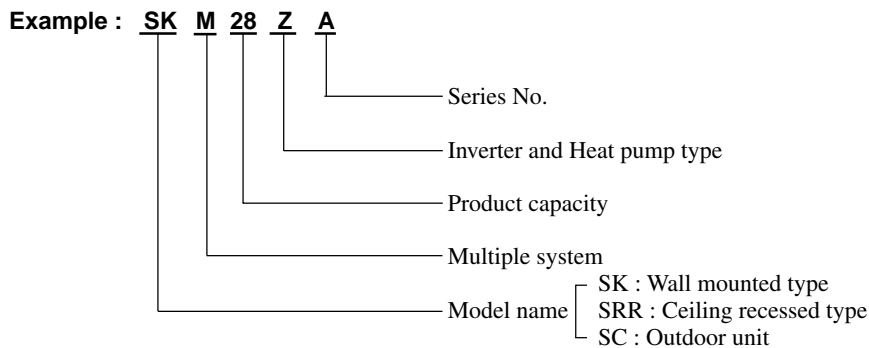

# SELECTION DATA

## Specifications

### (1) Indoor unit

#### (a) Wall mounted type

Models SKM22ZA, 25ZA, 28ZA

Item		Models		SKM22ZA	SKM25ZA	SKM28ZA
		W				
Cooling capacity		W		2200	2500	2800
Heating capacity		W		3200	3400	4000
Noise level	Cooling	Sound level	dB	Hi : 38 Lo : 29		Hi : 39 Lo : 31
		Power level		Hi : 52 Lo : 43		Hi : 53 Lo : 45
	Heating	Sound level		Hi : 39 Lo : 30		Hi : 40 Lo : 32
		Power level		Hi : 53 Lo : 44		Hi : 54 Lo : 46
Exterior dimensions Height × Width × Depth		mm		250 × 750 × 178		275 × 790 × 174
Color				Ivory white		
Net weight		kg		7.5		
Air handling equipment Fan type & Q'ty				Tangential fan × 1		
Motor		W		17		18
Air flow (at high)	Cooling	CMM		7.0		7.7
	Heating			7.5		9.1
Air filter, Q'ty				Polypropylene net × 2 (Washable)		
Operation switch				Wireless-Remote controller		
Room temperature control				M.C thermostat		
Pilot lamp				RUN (Green), TIMER (Yellow)		
Safety equipment				Frost protection, Serial error protection Fan moter error protection		
Refrigerant piping	O.D	Liquid line	mm (in)	φ 6.35 (1/4")		
		Gas line		φ 9.52 (3/8")		
	Connecting method			Flare connecting		
	Attached length of piping			Liquid line : 0.4m Gas line : 0.35m		
	Insulation			Necessary (Both Liquid & Gas lines)		
Drain hose				Connectable		
Accessories (including)				Mounting kit		
Optional parts				—		
Outdoor units to be combined				SCM45ZA, SCM68ZA, SCM80ZA		

Notes (1) The data are measured at the following conditions.

Operation DB	Item	Indoor air temperature		Outdoor air temperature		Standards
		DB	WB	DB	WB	
Cooling		27°C	19°C	35°C	24°C	ISO-T1, JIS C9612
Heating		20°C	—	7°C	6°C	ISO-T1, JIS C9612

(2) Capacity indicated is the rated capacity with one unit operating under ISO-T1 standards conditions.

**Models SKM32ZA, 40ZA, 50ZA**

Item		Models		SKM32ZA	SKM40ZA	SKM50ZA
		W				
Cooling capacity		W		3200	4000	5000
Heating capacity		W		4500	5400	6700
Noise level	Cooling	Sound level	dB	Hi : 40 Lo : 30	Hi : 42 Lo : 31	Hi : 43 Lo : 31
		Power level		Hi : 54 Lo : 44	Hi : 56 Lo : 45	Hi : 57 Lo : 45
	Heating	Sound level		Hi : 41 Lo : 32	Hi : 42 Lo : 32	Hi : 43 Lo : 31
		Power level		Hi : 55 Lo : 46	Hi : 56 Lo : 46	Hi : 57 Lo : 45
Exterior dimensions Height × Width × Depth		mm		275 × 790 × 174		275 × 790 × 189
Color				Ivory white		
Net weight		kg		8.0		9.0
Air handling equipment Fan type & Q'ty				Tangential fan × 1		
Motor		W		18		26
Air flow (at high)	Cooling	CMM		9.0	9.5	10
	Heating			10	10	10.5
Air filter, Q'ty				Polypropylene net × 2 (Washable)		
Operation switch				Wireless-Remote controller		
Room temperature control				M.C thermostat		
Pilot lamp				RUN (Green), TIMER (Yellow)		RUN (Green), TIMER (Yellow), ECONO (Orange), HI POWER (Green)
Safety equipment				Frost protection, Serial error protection Fan moter error protection		
Refrigerant piping	O.D	Liquid line	mm (in)	φ 6.35 (1/4")		
		Gas line		φ 12.7 (1/2")		
	Connecting method			Flare connecting		
	Attached length of piping			Liquid line : 0.4m Gas line : 0.35m		
Insulation			Necessary (Both Liquid & Gas lines)			
Drain hose				Connectable		
Accessories (including)				Mounting kit		
Optional parts				—		
Outdoor units to be combined				SCM45ZA, SCM68ZA, SCM80ZA		SCM68ZA, SCM80ZA

Notes (1) The data are measured at the following conditions.

Item	Indoor air temperature		Outdoor air temperature		Standards
	DB	WB	DB	WB	
Operation DB					
Cooling	27°C	19°C	35°C	24°C	ISO-T1, JIS C9612
Heating	20°C	—	7°C	6°C	ISO-T1, JIS C9612

(2) Capacity indicated is the rated capacity with one unit operating under ISO-T1 standards conditions.

**(b) Ceiling recessed type****Model SRRM40ZA**

Item		Model	SRRM40ZA
Cooling capacity		W	4000
Heating capacity		W	6000
Noise level	Cooling	Sound level	Hi : 41 Lo : 33
		Power level	Hi : 55 Lo : 47
	Heating	Sound level	Hi : 44 Lo : 34
		Power level	Hi : 58 Lo : 48
Exterior dimensions Height × Width × Depth		mm	230 × 740 × 455
Color			—
Net weight		kg	19
Air handling equipment Fan type & Q'ty			Multiblade centrifugal fan × 2
Motor		W	21
Air flow (at high)	Cooling	CMM	8.5
	Heating		9.5
Air filter, Q'ty			—
Operation switch			Wireless-Remote controller
Room temperature control			M.C thermostat
Pilot lamp			RUN (Green), TIMER (Yellow)
Safety equipment			Frost protection, Serial error protection Drain error protection
Refrigerant piping	O.D	Liquid line	φ 6.35 (1/4")
		Gas line	φ 12.7 (1/2")
	Connecting method		Flare connecting
	Attached length of piping		—
	Insulation		Necessary (Both Liquid & Gas lines)
Drain hose			Connectable
Accessories (including)			Mounting kit
Outdoor units to be combined			SCM68ZA, SCM80ZA

Notes (1) The data are measured at the following conditions.

Operation DB	Item	Indoor air temperature		Outdoor air temperature		Standards
		DB	WB	DB	WB	
Cooling		27°C	19°C	35°C	24°C	ISO-T1, JIS C9612
Heating		20°C	—	7°C	6°C	ISO-T1, JIS C9612

(2) Capacity indicated is the rated capacity with one unit operating under ISO-T1 standards conditions.

(2) Outdoor unit  
Model SCM45ZA

Item		Model	SCM45ZA
Cooling capacity		W	4500 (2000 ~ 5100)
Heating capacity		W	5600 (2200 ~ 6000)
Power source			1 Phase 220/240V 50Hz
Power consumption	Cooling	W	1820 (680 ~ 2050)
	Heating		1950 (650 ~ 2190)
Running current	Cooling	A	8.4/7.7
	Heating		9.0/8.2
Noise level	Sound level	dB	Cooling : 46 Heating : 48
	Power level		Cooling : 60 Heating : 62
Exterior dimensions Height × Width × Depth		mm	595 × 720 × 290
Color			Stucco white
Net weight		kg	36
Refrigerant equipment Compressor type & Q'ty			GR5490FD41 × 1
Motor		kW	1.2
Starting method			Direct start
Refrigerant control			Capillary tubes + Electric expansion valve
Refrigerant		kg	R22 1.3 (Pre-charged up to the piping length of 20m)
Refrigerant oil		ℓ	0.45 (BARREL FREEZE 32SAM)
Air handling equipment Fan type & Q'ty			Propeller fan × 2
Motor		W	24
Air flow (at high)		CMM	30
Shock & vibration absorber			Rubber (for compressor)
Safety equipment			Compressor overheat protection, Overcurrent protection High pressure protection, Serial signal error protection
Refrigerant piping	Size × Core × Number	mm (in)	Liquid line: φ 6.35 (1/4") × 2
			Gas line: φ 9.52 (3/8") × 2
	Connecting method		Flare connecting
	Attached length piping		—
Insulation			Necessary (Both Liquid & Gas lines)
Power source supply			Terminal block (Screw fixing type)
Connec- tion wiring	Size × Core number		1.5 mm <sup>2</sup> × 4 cores (Including earth cable)
	Connecting method		Terminal block (Screw fixing type)
Accessories (included)			Union : (φ 9.52 → φ 12.7) × 1 Installation sheet, Manual instruction
Indoor units to be combined			SKM22, 25, 28, 32, 40 type

Notes (1) The data are measured at the following conditions.

Operation	Item	Indoor air temperature		Outdoor air temperature		Standards
		DB	WB	DB	WB	
Cooling		27°C	19°C	35°C	24°C	ISO-T1, JIS C9612
Heating		20°C	—	7°C	6°C	ISO-T1, JIS C9612

(2) The values for capacity and power consumption shown in a range ( ) indicate the minimum and maximum of the range.

(3) If the piping length exceeds 20 m, additional charging is required. (20g/m)

(2) Outdoor unit

Model SCM68ZA

Item		Model	SCM68ZA
Cooling capacity		W	6800 (1800~7000)
Heating capacity		W	7300 (2000~7600)
Power source			1 Phase 220/230/240V 50Hz
Power consumption	Cooling	W	3230 (500~3400)
	Heating		2950 (500~3400)
Running current	Cooling	A	17.0/16.6/16.1
	Heating		17.0/16.6/16.1
Noise level	Sound level	dB	Cooling : 50/50/51 Heating : 52/52/52
	Power level		Cooling : 64/64/65 Heating : 66/66/66
Exterior dimensions Height × Width × Depth		mm	640 × 850 × 290
Color			Stucco white
Net weight		kg	53
Refrigerant equipment Compressor type & Q'ty			RM5516GA4 × 1
Motor		kW	1.5
Starting method			Direct start
Refrigerant control			Capillary tubes + Electric expansion valve + Thermal expansion valve
Refrigerant		kg	R22 1.95 (Pre-charged up to the piping length of 30m)
Refrigerant oil		ℓ	0.6 (BARREL FREEZE 32SAM)
Air handling equipment Fan type & Q'ty			Propeller fan × 1
Motor		W	37
Air flow (at high)		CMM	40
Shock & vibration absorber			Rubber (for compressor)
Safety equipment			Compressor overheat protection, Overcurrent protection Power transistor overheat protection
Refrigerant piping	Size × Core × Number	mm (in)	Liquid line: φ 6.35 (1/4") × 3 Gas line: φ 9.52 (3/8") × 2 + φ 12.7 (1/2") × 1
	Connecting method		Flare connecting
	Attached length piping		—
	Insulation		Necessary (Both Liquid & Gas lines)
Power source supply			Terminal block (Screw fixing type)
Connection wiring	Size × Core number		1.5 mm <sup>2</sup> × 4 cores (Including earth cable)
	Connecting method		Terminal block (Screw fixing type)
Accessories (included)			Union : (φ 9.52 → φ 12.7) × 2, (φ 12.7 → φ 9.52) × 1 Installation sheet, Manual instruction
Indoor units to be combined			SKM22, 25, 28, 32, 40, 50 type SRRM40 type

Notes (1) The data are measured at the following conditions.

Operation DB	Item	Indoor air temperature		Outdoor air temperature		Standards
		DB	WB	DB	WB	
Cooling		27°C	19°C	35°C	24°C	ISO-T1, JIS C9612
Heating		20°C	—	7°C	6°C	ISO-T1, JIS C9612

(2) The values for capacity and power consumption shown in a range ( ) indicate the minimum and maximum of the range.

(3) If the piping length exceeds 30 m, additional charging is required. (20g/m)

(2) Outdoor unit

Model SCM80ZA

Item		Model	SCM80ZA
Cooling capacity		W	8000 (1800~8600)
Heating capacity		W	9500 (2000~10800)
Power source			1 Phase 220/230/240V 50Hz
Power consumption	Cooling	W	3270 (750~3700)
	Heating		3140 (750~3800)
Running current	Cooling	A	18.0/17.2/16.4
	Heating		17.2/16.6/16.1
Noise level	Sound level	dB	Cooling : 48/48/49 Heating : 49/50/50
	Power level		Cooling : 62/62/63 Heating : 63/64/64
Exterior dimensions Height × Width × Depth		mm	845 × 880 × 340
Color			Polar white
Net weight		kg	80
Refrigerant equipment Compressor type & Q'ty			HV461X3-S12MS × 1
Motor		kW	1.8
Starting method			Direct start
Refrigerant control			Capillary tubes + Electric expansion valve × Thermal expansion valve
Refrigerant		kg	R22 2.6 (Pre-charged up to the piping length of 40m)
Refrigerant oil		ℓ	1.4 (SUNISO 4GSD)
Air handling equipment Fan type & Q'ty			Propeller fan × 1
Motor		W	55
Air flow (at high)		CMM	56
Shock & vibration absorber			Rubber (for compressor)
Safety equipment			Compressor overheat protection, Overcurrent protection Power transistor overheat protection
Refrigerant piping	Size × Core × Number	mm (in)	Liquid line: φ 6.35 (1/4") × 4 Gas line: φ 9.52 (3/8") × 2 + φ 12.7 (1/2") × 2
	Connecting method		Flare connecting
	Attached length piping		—
	Insulation		Necessary (Both Liquid & Gas lines)
Power source supply			Terminal block (Screw fixing type)
Connection wiring	Size × Core number		1.5 mm <sup>2</sup> × 4 cores (Including earth cable)
	Connecting method		Terminal block (Screw fixing type)
Accessories (included)			Union : (φ 9.52 → φ 12.7) × 2, (φ 12.7 → φ 9.52) × 2 Installation sheet, Manual instruction
Indoor units to be combined			SKM22, 25, 28, 32, 40, 50 type SRRM40 type

Notes (1) The data are measured at the following conditions.

Operation DB	Item	Indoor air temperature		Outdoor air temperature		Standards
		DB	WB	DB	WB	
Cooling		27°C	19°C	35°C	24°C	ISO-T1, JIS C9612
Heating		20°C	—	7°C	6°C	ISO-T1, JIS C9612

(2) The values for capacity and power consumption shown in a range ( ) indicate the minimum and maximum of the range.

(3) If the piping length exceeds 40 m, additional charging is required. (20g/m)



(1) Indoor unit

Models SKM22YA, 25YA, 40YA

Item		Models		SKM22YA	SKM25YA	SKM40YA
		W		2200	2500	4000
Noise level	Sound level	dB		Hi : 38	Lo : 29	Hi : 42 Lo : 31
	Power level			Hi : 52	Lo : 43	Hi : 56 Lo : 45
Exterior dimensions Height × Width × Depth		mm		250 × 750 × 178		275 × 790 × 174
Color				Ivory white		
Net weight		kg		7.5		8.0
Air handling equipment Fan type & Q'ty				Tangential fan × 1		
Motor		W		17		18
Air flow (at high)		CMM		7.0		9.5
Air filter, Q'ty				Polypropylene net × 2 (Washable)		
Operation switch				Wireless-Remote controller		
Room temperature control				M.C thermostat		
Pilot lamp				RUN (Green), TIMER (Yellow)		
Safety equipment				Frost protection, Serial error protection Fan motor error protection		
Refrigerant piping	O.D	Liquid line	mm (in)	φ 6.35 (1/4")		
		Gas line		φ 9.52 (3/8")	φ 12.7 (1/2")	
	Connecting method			Flare connecting		
	Attached length of piping			Liquid line : 0.4m Gas line : 0.35m		
	Insulation			Necessary (Both Liquid & Gas lines)		
Drain hose				Connectable		
Accessories (including)				Mounting kit		
Optional parts				—		
Outdoor units to be combined				SCM45YA, SCM68YA		

Notes (1) The data are measured at the following conditions.

Operation	Item	Indoor air temperature		Outdoor air temperature		Standards
		DB	WB	DB	WB	
Cooling		27°C	19°C	35°C	24°C	ISO-T1, JIS C9612

(2) Capacity indicated is the rated capacity with one unit operating under ISO-T1 standards conditions.

(2) Outdoor unit

Model SCM45YA

Item		Model	SCM45YA
Cooling capacity		W	4500 (2000 ~ 5100)
Power source			1 Phase 220/240V 50Hz
Power consumption		W	1820 (680~2050)
Running current		A	8.4/7.7
Noise level	Sound level	dB	46
	Power level		60
Exterior dimensions Height × Width × Depth		mm	595 × 720 × 290
Color			Stucco white
Net weight		kg	36
Refrigerant equipment Compressor type & Q'ty			GR5490FD41 × 1
Motor		kW	1.2
Starting method			Direct start
Refrigerant control			Capillary tubes + Electric expansion valve
Refrigerant		kg	R22 1.3 (Pre-charged up to the piping length of 20m)
Refrigerant oil		ℓ	0.45 (BARREL FREEZE 32SAM)
Air handling equipment Fan type & Q'ty			Propeller fan × 1
Motor		W	24
Air flow (at high)		CMM	26
Shock & vibration absorber			Rubber (for compressor)
Safety equipment			Compressor overheat protection, Overcurrent protection Serial signal error protection
Refrigerant piping	Size × Core × Number	mm (in)	Liquid line: φ 6.35 (1/4") × 2 Gas line: φ 9.52 (3/8") × 2
	Connecting method		Flare connecting
	Attached length piping		—
	Insulation		Necessary (Both Liquid & Gas lines)
Power source supply			Terminal block (Screw fixing type)
Connection wiring	Size × Core number		1.5 mm <sup>2</sup> × 4 cores (Including earth cable)
	Connecting method		Terminal block (Screw fixing type)
Accessories (included)			Union : (φ 9.52 → φ 12.7) × 1 Installation sheet, Manual instruction
Indoor units to be combined			SKM22, 25, 40 type

Notes (1) The data are measured at the following conditions.

Operation	Item	Indoor air temperature		Outdoor air temperature		Standards
		DB	WB	DB	WB	
Cooling		27°C	19°C	35°C	24°C	ISO-T1, JIS C9612

(2) The values for capacity and power consumption shown in a range ( ) indicate the minimum and maximum of the range.

(3) If the piping length exceeds 20m, additional charging is required. (20g/m)

(2) Outdoor unit

Model SCM68YA

Item		Model	SCM68YA
Cooling capacity		W	6800 (1800~7000)
Power source			1 Phase 220/230/240V 50Hz
Power consumption		W	3230 (500~3400)
Running current		A	17.0/16.6/16.1
Noise level	Sound level	dB	50/50/ 51
	Power level		64/64/65
Exterior dimensions Height × Width × Depth		mm	640 × 850 × 290
Color			Stucco white
Net weight		kg	53
Refrigerant equipment Compressor type & Q'ty			RM5516GA4 × 1
Motor		kW	1.5
Starting method			Direct start
Refrigerant control			Capillary tubes + Electric expansion valve + Thermal expansion valve
Refrigerant		kg	R22 1.95 (Pre-charged up to the piping length of 30m)
Refrigerant oil		ℓ	0.6 (BARREL FREEZE 32SAM)
Air handling equipment Fan type & Q'ty			Propeller fan × 1
Motor		W	37
Air flow (at high)		CMM	40
Shock & vibration absorber			Rubber (for compressor)
Safety equipment			Compressor overheat protection, Overcurrent protection Power transistor overheat protection
Refrigerant piping	Size × Core × Number	mm (in)	Liquid line: φ 6.35 (1/4") × 3 Gas line: φ 9.52 (3/8") × 2 + φ 12.7 (1/2") × 1
	Connecting method		Flare connecting
	Attached length piping		—
	Insulation		Necessary (Both Liquid & Gas lines)
Power source supply			Terminal block (Screw fixing type)
Connection wiring	Size × Core number		1.5 mm <sup>2</sup> × 4 cores (Including earth cable)
	Connecting method		Terminal block (Screw fixing type)
Accessories (included)			Union : (φ 9.52 → φ 12.7) × 2, (φ 12.7 → φ 9.52) × 1 Installation sheet, Manual instruction
Indoor units to be combined			SKM22, 25, 40 type

Notes (1) The data are measured at the following conditions.

Operation	Item	Indoor air temperature		Outdoor air temperature		Standards
		DB	WB	DB	WB	
Cooling		27°C	19°C	35°C	24°C	ISO-T1, JIS C9612

(2) The values for capacity and power consumption shown in a range ( ) indicate the minimum and maximum of the range.

(3) If the piping length exceeds 30m, additional charging is required. (20g/m)

**(3) Operation data 80 ZA**

- The combinations of the indoor units is indicated by numbers. They are read as follows.

(Example) SKM22ZA → 22 SKM50ZA → 50

- The capacity of the indoor units is shown by rooms. If this exceeds the maximum capacity of the outdoor unit, the demand capacity will be proportionally distributed.
- If units are to be combined, use the table below to make the proper selection.

**(a) Heating 80 ZA**

Indoor unit combination		Heating capacity (kW)							Power consumption (W)			Standard current (A)		
		Room heating capacity (kW)				Total capacity (kW)			Min.	Standard	Max.	220V	230V	240V
		A room	B room	C room	D room	Min.	Standard	Max.						
1 room	22	3.2				2.0	3.2	3.9	750	860	1110	4.7	4.5	4.4
	25	3.4				2.0	3.4	4.0	750	980	1220	5.4	5.2	5.0
	28	4.0				2.4	4.0	4.7	850	1120	1390	6.1	5.9	5.7
	32	4.5				2.4	4.5	5.6	850	1320	1740	7.2	7.0	6.8
	40	5.4				3.0	5.4	6.0	1050	1700	2020	9.3	9.0	8.7
	50	6.7				3.0	6.7	7.9	1050	2200	2780	12.0	11.6	11.3
2 room	22+22	2.9	2.9			3.5	5.8	6.7	1250	1900	2350	10.4	10.0	9.7
	22+25	2.9	3.3			3.5	6.2	7.3	1250	2050	2590	11.2	10.8	10.5
	22+28	2.9	3.8			3.5	6.7	7.9	1250	2200	2780	12.0	11.6	11.3
	22+32	2.9	4.1			3.5	7.0	8.3	1250	2400	3060	13.1	12.7	12.3
	22+40	2.8	5.2			3.5	8.0	9.2	1250	2780	3440	15.2	14.7	14.2
	22+50	2.7	6.2			3.5	8.9	10.1	1250	3220	3800	17.6	17.0	16.5
	25+25	3.35	3.35			3.5	6.7	7.9	1250	2200	2780	12.0	11.6	11.3
	25+28	3.3	3.6			3.5	6.9	8.2	1250	2340	2980	12.8	12.4	12.0
	25+32	3.2	4.2			3.5	7.4	8.7	1250	2540	3210	13.9	13.4	13.0
	25+40	3.2	5.1			3.5	8.3	9.6	1250	2920	3630	16.0	15.4	15.0
	25+50	3.0	5.9			3.5	8.9	10.2	1250	3220	3800	17.6	17.0	16.5
	28+28	3.6	3.6			3.5	7.2	8.5	1250	2500	3170	13.7	13.2	12.8
	28+32	3.6	4.1			3.5	7.7	9.0	1250	2580	3230	14.1	13.6	13.2
	28+40	3.5	5.1			3.5	8.6	9.9	1250	3070	3800	16.8	16.2	15.7
	28+50	3.2	5.7			3.5	8.9	10.2	1250	3210	3800	17.6	17.0	16.5
	32+32	4.1	4.1			3.5	8.2	9.5	1250	2880	3590	15.8	15.2	14.8
	32+40	4.0	4.9			3.5	8.9	10.1	1250	3220	3800	17.6	17.0	16.5
	32+50	3.5	5.5			3.5	9.0	10.3	1250	3210	3800	17.6	17.0	16.5
40+40	4.5	4.5			3.5	9.0	10.2	1250	3210	3800	17.6	17.0	16.5	
40+50	4.0	5.1			3.5	9.1	10.4	1250	3190	3800	17.5	16.9	16.3	
50+50	4.6	4.6			3.5	9.2	10.5	1250	3180	3800	17.4	16.8	16.3	
3 room	22+22+22	2.8	2.8	2.8		4.8	8.4	9.7	1750	2970	3690	16.3	15.7	15.2
	22+22+25	2.8	2.8	3.1		4.8	8.7	10.0	1750	3120	3800	17.1	16.5	16.0
	22+22+28	2.7	2.7	3.5		4.8	8.9	10.1	1750	3220	3800	17.6	17.0	16.5
	22+22+32	2.6	2.6	3.7		4.8	8.9	10.2	1750	3220	3800	17.6	17.0	16.5
	22+22+40	2.4	2.4	4.2		4.8	9.0	10.3	1750	3200	3800	17.5	16.9	16.4
	22+22+50	2.1	2.1	4.9		4.8	9.1	10.4	1750	3190	3800	17.5	16.9	16.3
	22+25+25	2.7	3.1	3.1		4.8	8.9	10.1	1750	3220	3800	17.6	17.0	16.5
	22+25+32	2.6	3.0	3.3		4.8	8.9	10.2	1750	3220	3800	17.6	17.0	16.5
	22+25+40	2.5	2.8	3.7		4.8	9.0	10.2	1750	3210	3800	17.6	17.0	16.5
	22+25+50	2.3	2.6	4.2		4.8	9.1	10.3	1750	3200	3800	17.5	16.9	16.4
	22+25+50	2.1	2.4	4.7		4.8	9.2	10.5	1750	3180	3800	17.4	16.8	16.3
	22+28+28	2.5	3.2	3.2		4.8	8.9	10.2	1750	3210	3800	17.6	17.0	16.5
	22+28+32	2.4	3.1	3.5		4.8	9.0	10.3	1750	3210	3800	17.6	17.0	16.5
	22+28+40	2.2	2.8	4.1		4.8	9.1	10.4	1750	3190	3800	17.5	16.9	16.3
	22+28+50	2.0	2.6	4.6		4.8	9.2	10.5	1750	3180	3800	17.4	16.8	16.3
	22+32+32	2.4	3.3	3.3		4.8	9.0	10.3	1750	3200	3800	17.5	16.9	16.4
	22+32+40	2.1	3.1	3.9		4.8	9.1	10.4	1750	3190	3800	17.5	16.9	16.3
	22+32+50	2.0	2.9	4.4		4.8	9.3	10.6	1750	3170	3800	17.4	16.8	16.2

Indoor unit combination		Heating capacity (kW) 80ZA							Power consumption (W)			Standard current (A)		
		Room heating capacity (kW)				Total capacity (kW)			Min.	Standard	Max.	220V	230V	240V
		A room	B room	C room	D room	Min.	Standard	Max.						
3 room	22+40+40	2.0	3.6	3.6		4.8	9.2	10.6	1750	3170	3800	17.4	16.8	16.2
	22+40+50	1.8	3.4	4.2		4.8	9.4	10.7	1750	3160	3800	17.3	16.7	16.2
	25+25+25	2.97	2.97	2.97		4.8	8.9	10.2	1750	3220	3800	17.6	17.0	16.5
	25+25+28	2.9	2.9	3.1		4.8	8.9	10.2	1750	3210	3800	17.6	17.0	16.5
	25+25+32	2.7	2.7	3.6		4.8	9.0	10.3	1750	3210	3800	17.6	17.0	16.5
	25+25+40	2.5	2.5	4.1		4.8	9.1	10.4	1750	3190	3800	17.5	16.9	16.3
	25+25+50	2.3	2.3	4.6		4.8	9.2	10.5	1750	3180	3800	17.4	16.8	16.3
	25+28+28	2.8	3.1	3.1		4.8	9.0	10.3	1750	3210	3800	17.6	17.0	16.5
	25+28+32	2.6	3.0	3.4		4.8	9.0	10.3	1750	3200	3800	17.5	16.9	16.4
	25+28+40	2.4	2.7	4.0		4.8	9.1	10.4	1750	3190	3800	17.5	16.9	16.3
	25+28+50	2.3	2.5	4.5		4.8	9.3	10.6	1750	3170	3800	17.4	16.8	16.2
	25+32+32	2.5	3.3	3.3		4.8	9.1	10.4	1750	3190	3800	17.5	16.9	16.3
	25+32+40	2.4	3.0	3.8		4.8	9.2	10.5	1750	3180	3800	17.4	16.8	16.3
	25+32+50	2.2	2.8	4.3		4.8	9.3	10.6	1750	3160	3800	17.3	16.7	16.2
	25+40+40	2.3	3.5	3.5		4.8	9.3	10.6	1750	3170	3800	17.4	16.8	16.2
	25+40+50	2.0	3.3	4.1		4.8	9.4	10.7	1750	3150	3800	17.3	16.7	16.1
	28+28+28	3.0	3.0	3.0		4.8	9.0	10.3	1750	3200	3800	17.5	16.9	16.4
	28+28+32	2.9	2.9	3.3		4.8	9.1	10.4	1750	3200	3800	17.5	16.9	16.4
	28+28+40	2.7	2.7	3.8		4.8	9.2	10.5	1750	3180	3800	17.4	16.8	16.3
	28+28+50	2.5	2.5	4.3		4.8	9.3	10.6	1750	3170	3800	17.4	16.8	16.2
	28+32+32	2.7	3.2	3.2		4.8	9.1	10.4	1750	3190	3800	17.5	16.9	16.3
	28+32+40	2.6	2.9	3.7		4.8	9.2	10.5	1750	3180	3800	17.4	16.8	16.3
	28+32+50	2.4	2.7	4.2		4.8	9.3	10.7	1750	3160	3800	17.3	16.7	16.2
	28+40+40	2.5	3.4	3.4		4.8	9.3	10.6	1750	3160	3800	17.3	16.7	16.2
	28+40+50	2.2	3.2	4.0		4.8	9.4	10.8	1750	3140	3800	17.2	16.6	16.1
	32+32+32	3.07	3.07	3.07		4.8	9.2	10.5	1750	3180	3800	17.4	16.8	16.3
	32+32+40	2.9	2.9	3.5		4.8	9.3	10.6	1750	3170	3800	17.4	16.8	16.2
	32+32+50	2.6	2.6	4.2		4.8	9.4	10.7	1750	3150	3800	17.3	16.7	16.1
32+40+40	2.6	3.4	3.4		4.8	9.4	10.7	1750	3160	3800	17.3	16.7	16.2	
40+40+40	3.17	3.17	3.17		4.8	9.5	10.8	1750	3140	3800	17.2	16.6	16.1	
4 room	22+22+22+22	2.28	2.28	2.28	2.28	5.6	9.1	10.4	1900	3200	3800	17.5	16.9	16.4
	22+22+22+25	2.2	2.2	2.2	2.5	5.6	9.1	10.4	1900	3190	3800	17.5	16.9	16.3
	22+22+22+28	2.1	2.1	2.1	2.8	5.6	9.1	10.4	1900	3190	3800	17.5	16.9	16.3
	22+22+22+32	2.1	2.1	2.1	2.9	5.6	9.2	10.5	1900	3180	3800	17.4	16.8	16.3
	22+22+22+40	1.9	1.9	1.9	3.6	5.6	9.3	10.6	1900	3170	3800	17.4	16.8	16.2
	22+22+22+50	1.8	1.8	1.8	4.0	5.6	9.4	10.8	1900	3150	3800	17.3	16.7	16.1
	22+22+25+25	2.15	2.15	2.4	2.4	5.6	9.1	10.4	1900	3190	3800	17.5	16.9	16.3
	22+22+25+28	2.1	2.1	2.4	2.6	5.6	9.2	10.5	1900	3180	3800	17.4	16.8	16.3
	22+22+25+32	2.0	2.0	2.3	2.9	5.6	9.2	10.5	1900	3170	3800	17.4	16.8	16.2
	22+22+25+40	1.9	1.9	2.1	3.4	5.6	9.3	10.7	1900	3160	3800	17.3	16.7	16.2
	22+22+25+50	1.8	1.8	2.0	3.9	5.6	9.5	10.8	1900	3140	3800	17.2	16.6	16.1
	22+22+28+28	2.0	2.0	2.6	2.6	5.6	9.2	10.5	1900	3180	3800	17.4	16.8	16.3
	22+22+28+32	2.0	2.0	2.5	2.8	5.6	9.3	10.6	1900	3170	3800	17.4	16.8	16.2
	22+22+28+40	1.8	1.8	2.4	3.4	5.6	9.4	10.7	1900	3160	3800	17.3	16.7	16.2
	22+22+32+32	1.9	1.9	2.75	2.75	5.6	9.3	10.6	1900	3160	3800	17.3	16.7	16.2
	22+22+32+40	1.8	1.8	2.6	3.2	5.6	9.4	10.8	1900	3150	3800	17.3	16.7	16.1
	22+25+25+25	2.0	2.4	2.4	2.4	5.6	9.2	10.5	1900	3180	3800	17.4	16.8	16.3
	22+25+25+28	2.0	2.3	2.3	2.6	5.6	9.2	10.5	1900	3180	3800	17.4	16.8	16.3
	22+25+25+32	2.0	2.2	2.2	2.9	5.6	9.3	10.6	1900	3170	3800	17.4	16.8	16.2
	22+25+25+40	1.8	2.1	2.1	3.4	5.6	9.4	10.7	1900	3160	3800	17.3	16.7	16.2
	22+25+28+28	2.0	2.3	2.3	2.5	5.6	9.3	10.6	1900	3170	3800	17.4	16.8	16.2
	22+25+28+32	1.9	2.2	2.4	2.8	5.6	9.3	10.6	1900	3160	3800	17.3	16.7	16.2
	22+25+28+40	1.8	2.0	2.3	3.3	5.6	9.4	10.7	1900	3150	3800	17.3	16.7	16.1
	22+25+32+32	1.9	2.1	2.7	2.7	5.6	9.4	10.7	1900	3160	3800	17.3	16.7	16.2
	22+25+32+40	1.8	2.0	2.6	3.1	5.6	9.5	10.8	1900	3140	3800	17.2	16.6	16.1

Indoor unit combination		Heating capacity (kW) 80ZA							Power consumption (W)			Standard current (A)		
		Room heating capacity (kW)				Total capacity (kW)			Min.	Standard	Max.	220V	230V	240V
		A room	B room	C room	D room	Min.	Standard	Max.						
4 room	22+28+28+28	1.8	2.5	2.5	2.5	5.6	9.3	10.6	1900	3170	3800	17.4	16.8	16.2
	22+28+28+32	1.8	2.4	2.4	2.7	5.6	9.3	10.7	1900	3160	3800	17.3	16.7	16.2
	22+28+28+40	1.8	2.2	2.2	3.2	5.6	9.4	10.8	1900	3140	3800	17.2	16.6	16.1
	22+28+32+32	1.9	2.3	2.6	2.6	5.6	9.4	10.7	1900	3150	3800	17.3	16.7	16.1
	22+32+32+32	1.9	2.5	2.5	2.5	5.6	9.4	10.8	1900	3140	3800	17.2	16.6	16.1
	25+25+25+25	2.3	2.3	2.3	2.3	5.6	9.2	10.5	1900	3180	3800	17.4	16.8	16.3
	25+25+25+28	2.3	2.3	2.3	2.4	5.6	9.3	10.6	1900	3170	3800	17.4	16.8	16.2
	25+25+25+32	2.2	2.2	2.2	2.7	5.6	9.3	10.6	1900	3160	3800	17.3	16.7	16.2
	25+25+25+40	2.0	2.0	2.0	3.4	5.6	9.4	10.7	1900	3150	3800	17.3	16.7	16.1
	25+25+28+28	2.2	2.2	2.45	2.45	5.6	9.3	10.6	1900	3170	3800	17.4	16.8	16.2
	25+25+28+32	2.1	2.1	2.4	2.7	5.6	9.3	10.7	1900	3160	3800	17.3	16.7	16.2
	25+25+28+40	2.0	2.0	2.2	3.2	5.6	9.4	10.8	1900	3140	3800	17.2	16.6	16.1
	25+25+32+32	2.1	2.1	2.6	2.6	5.6	9.4	10.7	1900	3150	3800	17.3	16.7	16.1
	25+28+28+28	2.1	2.4	2.4	2.4	5.6	9.3	10.7	1900	3160	3800	17.3	16.7	16.2
	25+28+28+32	2.1	2.3	2.3	2.7	5.6	9.4	10.7	1900	3150	3800	17.3	16.7	16.1
	25+28+32+32	2.0	2.2	2.6	2.6	5.6	9.4	10.8	1900	3150	3800	17.3	16.7	16.1
	28+28+28+28	2.35	2.35	2.35	2.35	5.6	9.4	10.7	1900	3160	3800	17.3	16.7	16.2
28+28+28+32	2.3	2.3	2.3	2.5	5.6	9.4	10.8	1900	3150	3800	17.3	16.7	16.1	
28+28+32+32	2.2	2.2	2.55	2.55	5.6	9.5	10.8	1900	3140	3800	17.2	16.6	16.1	

**(b) Cooling 80 ZA**

Indoor unit combination		Cooling capacity (kW)							Power consumption (W)			Standard current (A)		
		Room cooling capacity (kW)				Total capacity (kW)			Min.	Standard	Max.	220V	230V	240V
		A room	B room	C room	D room	Min.	Standard	Max.						
1 room	22	2.2				1.8	2.2	2.5	750	860	1020	4.7	4.5	4.3
	25	2.5				1.8	2.5	2.8	750	980	1140	5.4	5.2	4.9
	28	2.8				2.2	2.8	3.0	920	1100	1230	6.1	5.8	5.5
	32	3.2				2.2	3.2	3.5	920	1250	1420	6.9	6.6	6.3
	40	4.0				2.6	4.0	4.5	1080	1560	1830	8.6	8.2	7.8
	50	5.0				2.6	5.0	5.6	1080	1950	2270	10.7	10.3	9.8
2 room	22+22	2.2	2.2			3.0	4.4	5.0	1250	1720	2030	9.5	9.0	8.6
	22+25	2.2	2.5			3.0	4.7	5.3	1250	1840	2160	10.1	9.7	9.2
	22+28	2.2	2.8			3.0	5.0	5.6	1250	1950	2270	10.7	10.3	9.8
	22+32	2.2	3.2			3.0	5.4	6.0	1250	2110	2440	11.6	11.1	10.6
	22+40	2.2	4.0			3.0	6.2	6.8	1250	2420	2760	13.3	12.7	12.1
	22+50	2.1	4.9			3.0	7.0	7.6	1250	2810	3180	15.5	14.8	14.1
	25+25	2.5	2.5			3.0	5.0	5.6	1250	1950	2270	10.7	10.3	9.8
	25+28	2.5	2.8			3.0	5.3	5.9	1250	2070	2400	11.4	10.9	10.4
	25+32	2.5	3.2			3.0	5.7	6.3	1250	2220	2550	12.2	11.7	11.1
	25+40	2.5	4.0			3.0	6.5	7.1	1250	2540	2890	14.0	13.4	12.7
	25+50	2.4	4.7			3.0	7.1	7.7	1250	2930	3310	16.1	15.4	14.7
	28+28	2.8	2.8			3.0	5.6	6.2	1250	2180	2510	12.0	11.5	10.9
	28+32	2.8	3.2			3.0	6.0	6.6	1250	2340	2680	12.9	12.3	11.7
	28+40	2.8	4.0			3.0	6.8	7.4	1250	2660	3010	14.6	14.0	13.3
	28+50	2.6	4.6			3.0	7.2	7.8	1250	3000	3390	16.5	15.8	15.0
	32+32	3.2	3.2			3.0	6.4	7.0	1250	2500	2850	13.8	13.1	12.5
	32+40	3.1	3.9			3.0	7.0	7.6	1250	2810	3180	15.5	14.8	14.1
32+50	2.8	4.4			3.0	7.2	7.8	1250	3020	3420	16.6	15.9	15.1	
40+40	3.6	3.6			3.0	7.2	7.8	1250	3020	3420	16.6	15.9	15.1	
40+50	3.3	4.1			3.0	7.4	8.0	1250	3080	3470	16.9	16.2	15.4	
50+50	3.8	3.8			3.0	7.6	8.2	1250	3140	3530	17.3	16.5	15.7	

Indoor unit combination	Cooling capacity (kW) 80ZA							Power consumption (W)			Standard current (A)		
	Room cooling capacity (kW)				Total capacity (kW)			Min.	Standard	Max.	220V	230V	240V
	A room	B room	C room	D room	Min.	Standard	Max.						
22+22+22	2.2	2.2	2.2		4.2	6.6	7.2	1750	2580	2930	14.2	13.6	12.9
22+22+25	2.2	2.2	2.5		4.2	6.9	7.5	1750	2700	3050	14.9	14.2	13.5
22+22+28	2.1	2.1	2.8		4.2	7.0	7.6	1750	2810	3180	15.5	14.8	14.1
22+22+32	2.1	2.1	2.9		4.2	7.1	7.7	1750	2970	3360	16.3	15.6	14.9
22+22+40	1.9	1.9	3.5		4.2	7.3	7.9	1750	3040	3430	16.7	16.0	15.2
22+22+50	1.8	1.8	3.9		4.2	7.5	8.1	1750	3100	3490	17.1	16.3	15.5
22+25+25	2.2	2.4	2.4		4.2	7.0	7.6	1750	2810	3180	15.5	14.8	14.1
22+25+28	2.1	2.4	2.6		4.2	7.1	7.7	1750	2930	3310	16.1	15.4	14.7
22+25+32	2.0	2.3	2.9		4.2	7.2	7.8	1750	3000	3390	16.5	15.8	15.0
22+25+40	1.8	2.1	3.4		4.2	7.3	7.9	1750	3060	3460	16.8	16.1	15.3
22+25+50	1.7	1.9	3.9		4.2	7.5	8.1	1750	3120	3520	17.2	16.4	15.6
22+28+28	2.0	2.6	2.6		4.2	7.2	7.8	1750	3000	3390	16.5	15.8	15.0
22+28+32	1.9	2.5	2.8		4.2	7.2	7.8	1750	3020	3420	16.6	15.9	15.1
22+28+40	1.8	2.3	3.3		4.2	7.4	8.0	1750	3080	3470	16.9	16.2	15.4
22+28+50	1.7	2.1	3.8		4.2	7.6	8.2	1750	3140	3530	17.3	16.5	15.7
22+32+32	1.9	2.7	2.7		4.2	7.3	7.9	1750	3040	3430	16.7	16.0	15.2
22+32+40	1.8	2.6	3.1		4.2	7.5	8.1	1750	3100	3490	17.1	16.3	15.5
22+32+50	1.6	2.4	3.7		4.2	7.7	8.3	1750	3160	3550	17.4	16.6	15.8
22+40+40	1.6	3.0	3.0		4.2	7.6	8.2	1750	3160	3560	17.4	16.6	15.8
22+40+50	1.5	2.8	3.5		4.2	7.8	8.4	1750	3220	3620	17.7	16.9	16.1
25+25+25	2.4	2.4	2.4		4.2	7.2	7.7	1750	2930	3310	16.1	15.4	14.7
25+25+28	2.3	2.3	2.6		4.2	7.2	7.8	1750	3000	3390	16.5	15.8	15.0
25+25+32	2.2	2.2	2.8		4.2	7.2	7.8	1750	3020	3420	16.6	15.9	15.1
25+25+40	2.1	2.1	3.2		4.2	7.4	8.0	1750	3080	3470	16.9	16.2	15.4
25+25+50	1.9	1.9	3.8		4.2	7.6	8.2	1750	3140	3530	17.3	16.5	15.7
25+28+28	2.2	2.5	2.5		4.2	7.2	7.8	1750	3020	3420	16.6	15.9	15.1
25+28+32	2.1	2.4	2.8		4.2	7.3	7.9	1750	3040	3430	16.7	16.0	15.2
25+28+40	2.0	2.3	3.2		4.2	7.5	8.1	1750	3100	3490	17.1	16.3	15.5
25+28+50	1.9	2.1	3.7		4.2	7.7	8.3	1750	3160	3550	17.4	16.6	15.8
25+32+32	2.0	2.7	2.7		4.2	7.4	8.0	1750	3060	3450	16.8	16.1	15.3
25+32+40	1.9	2.5	3.1		4.2	7.5	8.1	1750	3120	3520	17.2	16.4	15.6
25+32+50	1.8	2.3	3.6		4.2	7.7	8.3	1750	3180	3580	17.5	16.7	15.9
25+40+40	1.9	2.9	2.9		4.2	7.7	8.3	1750	3180	3580	17.5	16.7	15.9
25+40+50	1.7	2.7	3.5		4.2	7.9	8.5	1750	3240	3640	17.8	17.0	16.2
28+28+28	2.4	2.4	2.4		4.2	7.2	7.9	1750	3040	3430	16.7	16.0	15.2
28+28+32	2.4	2.4	2.6		4.2	7.4	8.0	1750	3060	3450	16.8	16.1	15.3
28+28+40	2.2	2.2	3.1		4.2	7.5	8.1	1750	3120	3520	17.2	16.4	15.6
28+28+50	2.0	2.0	3.7		4.2	7.7	8.3	1750	3180	3580	17.5	16.7	15.9
28+32+32	2.2	2.6	2.6		4.2	7.4	8.0	1750	3080	3470	16.9	16.2	15.4
28+32+40	2.1	2.5	3.0		4.2	7.6	8.2	1750	3140	3530	17.3	16.5	15.7
28+32+50	2.0	2.3	3.5		4.2	7.8	8.4	1750	3200	3590	17.6	16.8	16.0
28+40+40	2.0	2.9	2.9		4.2	7.8	8.4	1750	3200	3590	17.6	16.8	16.0
28+40+50	1.9	2.7	3.4		4.2	8.0	8.6	1750	3260	3650	17.9	17.1	16.3
32+32+32	2.5	2.5	2.5		4.2	7.5	8.1	1750	3120	3520	17.2	16.4	15.6
32+32+40	2.4	2.4	2.9		4.2	7.7	8.3	1750	3160	3550	17.4	16.6	15.8
32+32+50	2.2	2.2	3.5		4.2	7.9	8.5	1750	3240	3640	17.8	17.0	16.2
32+40+40	2.2	2.8	2.8		4.2	7.8	8.4	1750	3220	3620	17.7	16.9	16.1
40+40+40	2.7	2.7	2.7		4.2	8.1	8.6	1750	3270	3700	18.0	17.2	16.4

3 room

Indoor unit combination	Cooling capacity (kW) 80ZA							Power consumption (W)			Standard current (A)		
	Room Cooling capacity (kW)				Total capacity (kW)			Min.	Standard	Max.	220V	230V	240V
	A room	B room	C room	D room	Min.	Standard	Max.						
22+22+22+22	1.8	1.8	1.8	1.8	5.0	7.2	8.0	2100	3060	3450	16.8	16.1	15.3
22+22+22+25	1.8	1.8	1.8	2.0	5.0	7.4	8.0	2100	3080	3470	16.9	16.2	15.4
22+22+22+28	1.8	1.8	1.8	2.1	5.0	7.5	8.1	2100	3100	3490	17.1	16.3	15.5
22+22+22+32	1.7	1.7	1.7	2.5	5.0	7.6	8.2	2100	3120	3510	17.2	16.4	15.6
22+22+22+40	1.6	1.6	1.6	2.9	5.0	7.7	8.3	2100	3180	3580	17.5	16.7	15.9
22+22+22+50	1.5	1.5	1.5	3.4	5.0	7.9	8.5	2100	3240	3640	17.8	17.0	16.2
22+22+25+25	1.8	1.8	2.0	2.0	5.0	7.6	8.1	2100	3100	3490	17.1	16.3	15.5
22+22+25+28	1.7	1.7	2.0	2.2	5.0	7.6	8.1	2100	3120	3520	17.2	16.4	15.6
22+22+25+32	1.7	1.7	1.9	2.3	5.0	7.6	8.2	2100	3140	3530	17.3	16.5	15.7
22+22+25+40	1.6	1.6	1.8	2.8	5.0	7.8	8.4	2100	3200	3590	17.6	16.8	16.0
22+22+25+50	1.5	1.5	1.7	2.3	5.0	8.0	8.6	2100	3270	3670	18.0	17.2	16.4
22+22+28+28	1.7	1.7	2.1	2.1	5.0	7.6	8.2	2100	3140	3530	17.3	16.5	15.7
22+22+28+32	1.6	1.6	2.1	2.4	5.0	7.7	8.3	2100	3160	3550	17.4	16.6	15.8
22+22+28+40	1.5	1.5	2.0	2.8	5.0	7.8	8.4	2100	3220	3620	17.7	16.9	16.1
22+22+32+32	1.6	1.6	2.3	2.3	5.0	7.8	8.4	2100	3200	3590	17.6	16.8	16.0
22+22+32+40	1.5	1.5	2.2	2.7	5.0	7.9	8.5	2100	3240	3640	17.8	17.0	16.2
22+25+25+25	1.8	1.9	1.9	1.9	5.0	7.5	8.1	2100	3120	3520	17.2	16.4	15.6
22+25+25+28	1.7	1.9	1.9	2.1	5.0	7.6	8.2	2100	3140	3530	17.3	16.5	15.7
22+25+25+32	1.6	1.9	1.9	2.3	5.0	7.7	8.3	2100	3160	3550	17.4	16.6	15.8
22+25+25+40	1.5	1.7	1.7	2.9	5.0	7.8	8.4	2100	3220	3620	17.7	16.9	16.1
22+25+28+28	1.6	1.9	2.1	2.1	5.0	7.7	8.3	2100	3160	3550	17.4	16.6	15.8
22+25+28+32	1.6	1.8	2.0	2.3	5.0	7.7	8.3	2100	3180	3580	17.5	16.7	15.9
22+25+28+40	1.5	1.7	1.9	2.8	5.0	7.9	8.5	2100	3240	3640	17.8	17.0	16.2
22+25+32+32	1.5	1.9	2.2	2.2	5.0	7.8	8.4	2100	3220	3620	17.7	16.9	16.1
22+25+32+40	1.5	1.7	2.2	2.6	5.0	8.0	8.6	2100	3270	3670	18.0	17.2	16.4
22+28+28+28	1.7	2.0	2.0	2.0	5.0	7.7	8.3	2100	3180	3580	17.5	16.7	15.9
22+28+28+32	1.6	2.0	2.0	2.2	5.0	7.8	8.4	2100	3200	3590	17.6	16.8	16.0
22+28+28+40	1.5	1.9	1.9	2.7	5.0	8.0	8.6	2100	3260	3650	17.9	17.1	16.3
22+28+32+32	1.5	1.8	2.2	2.2	5.0	7.9	8.5	2100	3240	3640	17.8	17.0	16.2
22+32+32+32	1.4	2.2	2.2	2.2	5.0	8.0	8.6	2100	3260	3650	17.9	17.1	16.3
25+25+25+25	1.9	1.9	1.9	1.9	5.0	7.6	8.2	2100	3140	3530	17.3	16.5	15.7
25+25+25+28	1.9	1.9	1.9	2.0	5.0	7.7	8.3	2100	3160	3550	17.4	16.6	15.8
25+25+25+32	1.8	1.8	1.8	2.3	5.0	7.7	8.3	2100	3180	3580	17.5	16.7	15.9
25+25+25+40	1.7	1.7	1.7	2.8	5.0	7.9	8.5	2100	3240	3640	17.8	17.0	16.2
25+25+28+28	1.8	1.8	2.0	2.0	5.0	7.6	8.3	2100	3180	3580	17.5	16.7	15.9
25+25+28+32	1.8	1.8	2.0	2.2	5.0	7.8	8.4	2100	3200	3590	17.6	16.8	16.0
25+25+28+40	1.7	1.7	1.9	2.7	5.0	8.0	8.6	2100	3260	3650	17.9	17.1	16.3
25+25+32+32	1.7	1.7	2.2	2.2	5.0	7.8	8.5	2100	3240	3630	17.8	17.0	16.2
25+28+28+28	1.8	2.0	2.0	2.0	5.0	7.8	8.4	2100	3200	3590	17.6	16.8	16.0
25+28+28+32	1.7	2.0	2.0	2.2	5.0	7.9	8.5	2100	3220	3610	17.7	16.9	16.1
25+28+32+32	1.6	1.9	2.2	2.2	5.0	7.9	8.5	2100	3260	3660	17.9	17.1	16.3
28+28+28+28	1.95	1.95	1.95	1.95	5.0	7.8	8.4	2100	3220	3620	17.7	16.9	16.1
28+28+28+32	1.9	1.9	1.9	2.2	5.0	7.9	8.5	2100	3240	3640	17.8	17.0	16.2
28+28+32+32	1.9	1.9	2.1	2.1	5.0	8.0	8.6	2100	3270	3700	18.0	17.2	16.4



Item		Model	SCM80ZA
Indoor intake air temperature (Upper, lower limits)		Refer to the selection chart.	
Outdoor air temperature (Upper, lower limits)			
Indoor units that can be used in combination	Number of connected units	3 to 4 units	
	Total of indoor Units (class kW)	12kW	
Total length for all rooms		Max. 60m	
Length for one indoor unit		Max. 25m	
Difference in height between indoor and outdoor units	When above outdoor unit (B)	Max. 10m	
	When below outdoor unit (A)	Max. 15m	
Difference in height between indoor units (C)		Max. 25m	
Compressor stop/start frequency	1 cycle time	6 min or more (from stop to stop or from start to start)	
	Stop time	3 min or more	
Power source voltage	Voltage fluctuation	Within $\pm 10\%$ of rated voltage	
	Voltage drop during start	Within $\pm 15\%$ of rated voltage	
	Interval unbalance	Within $\pm 3\%$ of rated voltage	

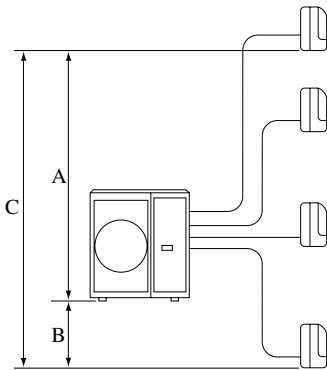

**(3) Operation data 68 ZA**

- The combinations of the indoor units is indicated by numbers. They are read as follows.  
(Example) SKM22ZA → 22 SKM50ZA → 50
- The capacity of the indoor units is shown by rooms. If this exceeds the maximum capacity of the outdoor unit, the demand capacity will be proportionally distributed.
- If units are to be combined, use the table below to make the proper selection.

**(a) Heating 68 ZA**

Indoor unit combination	Heating capacity (kW)						Power consumption (W)			Standard current (A)			
	Room heating capacity (kW)			Total capacity (kW)			Min.	Standard	Max.	220V	230V	240V	
	A room	B room	C room	Min.	Standard	Max.							
1 room	22	3.2		2.0	3.2	3.9	500	600	760	3.5	3.4	3.3	
	25	3.4		2.0	3.4	4.0	500	830	1,030	4.8	4.7	4.5	
	28	4.0		2.4	4.0	4.7	700	1,050	1,300	6.0	5.9	5.7	
	32	4.5		2.4	4.5	5.6	700	1,340	1,770	7.7	7.5	7.3	
	40	5.4		3.0	5.4	6.0	950	1,910	2,280	11.0	10.7	10.4	
2 room	50	6.7		3.0	6.7	7.0	950	2,630	2,980	15.2	14.8	14.4	
	22+22	2.95	2.95	3.3	5.9	6.4	1,200	2,200	2,580	12.7	12.4	12.0	
	22+25	2.9	3.4	3.3	6.3	6.7	1,200	2,420	2,790	13.9	13.6	13.2	
	22+28	2.9	3.8	3.3	6.7	7.0	1,200	2,630	2,980	15.2	14.8	14.4	
	22+32	2.7	4.0	3.3	6.7	7.1	1,200	2,920	3,390	16.8	16.4	15.9	
	22+40	2.4	4.4	3.3	6.8	7.2	1,200	3,000	3,400	17.3	16.9	16.4	
	22+50	2.1	4.9	3.3	7.0	7.3	1,200	2,990	3,400	17.2	16.8	16.3	
	25+25	3.35	3.35	3.3	6.7	7.0	1,200	2,630	2,980	15.2	14.8	14.4	
	25+28	3.2	3.5	3.3	6.7	7.1	1,200	2,850	3,300	16.4	16.0	15.6	
	25+32	3.0	3.8	3.3	6.8	7.1	1,200	3,010	3,400	17.3	16.9	16.4	
	25+40	2.7	4.2	3.3	6.9	7.2	1,200	3,000	3,400	17.3	16.9	16.4	
	25+50	2.3	4.7	3.3	7.0	7.3	1,200	2,980	3,400	17.2	16.8	16.3	
	28+28	3.4	3.4	3.3	6.8	7.1	1,200	3,010	3,400	17.3	16.9	16.4	
	28+32	3.2	3.6	3.3	6.8	7.2	1,200	3,000	3,400	17.3	16.9	16.4	
	28+40	2.8	4.1	3.3	6.9	7.2	1,200	2,990	3,400	17.2	16.8	16.3	
	28+50	2.5	4.5	3.3	7.0	7.4	1,200	2,980	3,400	17.2	16.8	16.3	
	32+32	3.45	3.45	3.3	6.9	7.2	1,200	3,000	3,400	17.3	16.9	16.4	
	32+40	3.1	3.9	3.3	7.0	7.3	1,200	2,990	3,400	17.2	16.8	16.3	
	32+50	2.8	4.3	3.3	7.1	7.4	1,200	2,970	3,380	17.1	16.7	16.2	
	40+40	3.55	3.55	3.3	7.1	7.4	1,200	2,980	3,390	17.2	16.8	16.3	
40+50	3.2	4.0	3.3	7.2	7.5	1,200	2,960	3,360	17.1	16.6	16.2		
3 room	22+22+22	2.3	2.3	2.3	4.5	6.9	7.2	1,650	3,000	3,400	17.3	16.9	16.4
	22+22+25	2.2	2.2	2.5	4.5	6.9	7.2	1,650	2,990	3,400	17.2	16.8	16.3
	22+22+28	2.1	2.1	2.8	4.5	7.0	7.3	1,650	2,990	3,400	17.2	16.8	16.3
	22+22+32	2.0	2.0	3.0	4.5	7.0	7.3	1,650	2,980	3,400	17.2	16.8	16.3
	22+22+40	1.9	1.9	3.3	4.5	7.1	7.4	1,650	2,970	3,380	17.1	16.7	16.2
	22+22+50	1.7	1.7	3.9	4.5	7.3	7.6	1,650	2,950	3,340	17.0	16.6	16.1
	22+25+25	2.2	2.4	2.4	4.5	7.0	7.3	1,650	2,990	3,400	17.2	16.8	16.3
	22+25+28	2.1	2.3	2.6	4.5	7.0	7.3	1,650	2,980	3,400	17.2	16.8	16.3
	22+25+32	2.0	2.2	2.9	4.5	7.1	7.4	1,650	2,980	3,390	17.2	16.8	16.3
	22+25+40	1.8	2.1	3.3	4.5	7.2	7.5	1,650	2,970	3,370	17.1	16.7	16.2
	22+28+28	2.0	2.5	2.5	4.5	7.0	7.4	1,650	2,980	3,400	17.2	16.8	16.3
	22+28+32	1.9	2.4	2.8	4.5	7.1	7.4	1,650	2,970	3,380	17.1	16.7	16.2
	22+28+40	1.8	2.2	3.2	4.5	7.2	7.5	1,650	2,960	3,360	17.1	16.6	16.2
	22+32+32	1.8	2.7	2.7	4.5	7.2	7.5	1,650	2,970	3,370	17.1	16.7	16.2
	22+32+40	1.7	2.5	3.1	4.5	7.3	7.6	1,650	2,950	3,340	17.0	16.6	16.1
	25+25+25	2.33	2.33	2.33	4.5	7.0	7.3	1,650	2,980	3,400	17.2	16.8	16.3
	25+25+28	2.2	2.2	2.6	4.5	7.0	7.4	1,650	2,980	3,400	17.2	16.8	16.3
	25+25+32	2.2	2.2	2.7	4.5	7.1	7.4	1,650	2,970	3,380	17.1	16.7	16.2
	25+25+40	2.0	2.0	3.2	4.5	7.2	7.5	1,650	2,960	3,360	17.1	16.6	16.2
	25+28+28	2.1	2.5	2.5	4.5	7.1	7.4	1,650	2,970	3,380	17.1	16.7	16.2
28+28+32	2.1	2.3	2.7	4.5	7.1	7.5	1,650	2,970	3,370	17.1	16.7	16.2	
25+28+40	2.0	2.2	3.1	4.5	7.3	7.6	1,650	2,960	3,350	17.1	16.6	16.2	
25+32+32	2.0	2.6	2.6	4.5	7.2	7.5	1,650	2,960	3,360	17.1	16.6	16.2	

Indoor unit combination		Heating capacity (kW) 68ZA						Power consumption (W)			Standard current (A)		
		Room heating capacity (kW)			Total capacity (kW)			Min.	Standard	Max.	220V	230V	240V
		A room	B room	C room	Min.	Standard	Max.						
3 room	28+28+28	2.37	2.37	2.37	4.5	7.1	7.4	1,650	2,970	3,380	17.1	16.7	16.2
	28+28+32	2.3	2.3	2.6	4.5	7.2	7.5	1,650	2,960	3,360	17.1	16.6	16.2
	28+28+40	2.1	2.1	3.0	4.5	7.3	7.6	1,650	2,950	3,340	17.0	16.6	16.1
	28+32+32	2.2	2.5	2.5	4.5	7.2	7.6	1,650	2,960	3,350	17.1	16.6	16.2
	32+32+32	2.43	2.43	2.43	4.5	7.3	7.6	1,650	2,950	3,340	17.0	16.6	16.1

**(b) Cooling 68 ZA**

Indoor unit combination		Cooling capacity (kW)						Power consumption (W)			Standard current (A)		
		Room cooling capacity (kW)			Total capacity (kW)			Min.	Standard	Max.	220V	230V	240V
		A room	B room	C room	Min.	Standard	Max.						
1 room	22	2.2			1.8	2.2	2.5	500	600	700	3.2	3.1	3.0
	25	2.5			1.8	2.5	2.8	500	750	870	3.9	3.9	3.7
	28	2.8			2.2	2.8	3.0	750	900	1,000	4.7	4.6	4.5
	32	3.2			2.2	3.2	3.5	750	1,100	1,250	5.8	5.7	5.5
	40	4.0			2.6	4.0	4.5	1,050	1,500	1,750	7.9	7.7	7.5
	50	5.0			2.6	5.0	5.6	1,050	2,000	2,330	10.5	10.3	10.0
2 room	22+22	2.2	2.2		2.8	4.4	5.0	1,200	1,700	2,010	8.9	8.7	8.5
	22+25	2.2	2.5		2.8	4.7	5.3	1,200	1,850	2,170	9.7	9.5	9.2
	22+28	2.2	2.8		2.8	5.0	5.6	1,200	2,000	2,330	10.5	10.3	10.0
	22+32	2.2	3.2		2.8	5.4	6.0	1,200	2,200	2,550	11.6	11.3	11.0
	22+40	2.1	3.9		2.8	6.0	6.2	1,200	2,600	2,810	13.7	13.4	13.0
	22+50	1.9	4.3		2.8	6.2	6.4	1,200	2,830	3,060	14.9	14.5	14.1
	25+25	2.5	2.5		2.8	5.0	5.6	1,200	2,000	2,330	10.5	10.3	10.0
	25+28	2.5	2.8		2.8	5.3	5.9	1,200	2,150	2,500	11.3	11.0	10.7
	25+32	2.5	3.2		2.8	5.7	6.1	1,200	2,350	2,620	12.4	12.1	11.7
	25+40	2.3	3.7		2.8	6.0	6.2	1,200	2,710	2,930	14.3	13.9	13.5
	25+50	2.1	4.2		2.8	6.3	6.5	1,200	2,880	3,110	15.2	14.8	14.4
	28+28	2.8	2.8		2.8	5.6	6.1	1,200	2,300	2,610	12.1	11.8	11.5
	28+32	2.8	3.2		2.8	6.0	6.2	1,200	2,500	2,700	13.2	12.8	12.5
	28+40	2.5	3.6		2.8	6.1	6.3	1,200	2,760	2,990	14.5	14.2	13.8
	28+50	2.3	4.1		2.8	6.4	6.6	1,200	2,930	3,170	15.4	15.1	14.6
	32+32	3.0	3.0		2.8	6.0	6.2	1,200	2,700	2,920	14.2	13.9	13.5
32+40	2.8	3.4		2.8	6.2	6.4	1,200	2,830	3,060	14.9	14.5	14.1	
32+50	2.5	4.0		2.8	6.5	6.7	1,200	3,000	3,240	15.8	15.4	15.0	
40+40	3.2	3.2		2.8	6.4	6.6	1,200	2,960	3,200	15.6	15.2	14.8	
40+50	3.0	3.7		2.8	6.7	6.9	1,200	3,130	3,380	16.5	16.1	15.6	
3 room	22+22+22	2.03	2.03	2.03	4.0	6.1	6.3	1,650	2,730	2,950	14.4	14.0	13.6
	22+22+25	1.9	1.9	2.3	4.0	6.1	6.3	1,650	2,780	3,010	14.6	14.3	13.9
	22+22+28	1.9	1.9	2.4	4.0	6.2	6.4	1,650	2,830	3,060	14.9	14.5	14.1
	22+22+32	1.8	1.8	2.7	4.0	6.3	6.5	1,650	2,900	3,140	15.3	14.9	14.5
	22+22+40	1.7	1.7	3.1	4.0	6.5	6.7	1,650	3,030	3,280	15.9	15.6	15.1
	22+22+50	1.6	1.6	3.6	4.0	6.8	7.0	1,650	3,200	3,400	16.8	16.4	15.9
	22+25+25	1.8	2.2	2.2	4.0	6.2	6.4	1,650	2,830	3,060	14.9	14.5	14.1
	22+25+28	1.8	2.1	2.4	4.0	6.3	6.5	1,650	2,880	3,110	15.2	14.8	14.4
	22+25+32	1.8	2.0	2.6	4.0	6.4	6.6	1,650	2,950	3,190	15.5	15.2	14.7
	22+25+40	1.7	1.9	3.0	4.0	6.6	6.8	1,650	3,080	3,330	16.2	15.8	15.4
	22+28+28	1.8	2.3	2.3	4.0	6.4	6.6	1,650	2,930	3,170	15.4	15.1	14.6
	22+28+32	1.7	2.2	2.5	4.0	6.5	6.7	1,650	3,000	3,240	15.8	15.4	15.0
	22+28+40	1.6	2.1	3.0	4.0	6.7	6.9	1,650	3,130	3,380	16.5	16.1	15.6
	22+32+32	1.6	2.5	2.5	4.0	6.6	6.8	1,650	3,070	3,320	16.2	15.8	15.3
	22+32+40	1.6	2.3	2.9	4.0	6.8	7.0	1,650	3,200	3,400	16.8	16.4	15.9
	25+25+25	2.1	2.1	2.1	4.0	6.3	6.5	1,650	2,880	3,110	15.2	14.8	14.4
25+25+28	2.1	2.1	2.2	4.0	6.4	6.6	1,650	2,930	3,170	15.4	15.1	14.6	
25+25+32	2.0	2.0	2.5	4.0	6.5	6.7	1,650	3,000	3,240	15.8	15.4	15.0	
25+25+40	1.9	1.9	2.9	4.0	6.7	6.9	1,650	3,130	3,380	16.5	16.1	15.6	

Indoor unit combination		Cooling capacity (kW) 68ZA						Power consumption (W)			Standard current (A)		
		Room cooling capacity (kW)			Total capacity (kW)			Min.	Standard	Max.	220V	230V	240V
		A room	B room	C room	Min.	Standard	Max.						
3 room	25+28+28	2.0	2.2	2.2	4.0	6.4	6.6	1,650	2980	3220	15.7	15.3	14.9
	25+28+32	1.9	2.1	2.5	4.0	6.5	6.7	1,650	3050	3300	16.0	15.7	15.2
	25+28+40	1.8	2.0	2.9	4.0	6.7	6.9	1,650	3180	3400	16.7	16.3	15.8
	25+32+32	1.8	2.4	2.4	4.0	6.6	6.8	1,650	3120	3370	16.4	16.0	15.6
	28+28+28	2.17	2.17	2.17	4.0	6.5	6.7	1,650	3030	3280	15.9	15.6	15.1
	28+28+32	2.1	2.1	2.4	4.0	6.6	6.8	1,650	3100	3350	16.3	15.9	15.5
	28+28+40	2.0	2.0	2.8	4.0	6.8	7.0	1,650	3230	3400	17.0	16.6	16.1
	28+32+32	2.1	2.3	2.3	4.0	6.7	6.9	1,650	3170	3400	16.7	16.3	15.8
	32+32+32	2.27	2.27	2.27	4.0	6.8	7.0	1,650	3230	3400	17.0	16.6	16.1

## Range of usage & limitations

Model		SCM68ZA
Item		
Indoor intake air temperature (Upper, lower limits)		Refer to the selection chart.
Outdoor air temperature (Upper, lower limits)		
Indoor units that can be used in combination	Number of connected units	2 to 3 units
	Total of indoor Units (class kW)	9.6kW
Total length for all rooms		Max. 40m
Length for one indoor unit		Max. 25m
Difference in height between indoor and outdoor units	When above outdoor unit (B)	Max. 10m
	When below outdoor unit (A)	Max. 15m
Difference in height between indoor units (C)		Max. 25m
Compressor stop/start frequency	1 cycle time	6 min or more (from stop to stop or from start to start)
	Stop time	3 min or more
Power source voltage	Voltage fluctuation	Within $\pm 10\%$ of rated voltage
	Voltage drop during start	Within $\pm 15\%$ of rated voltage
	Interval unbalance	Within $\pm 3\%$ of rated voltage

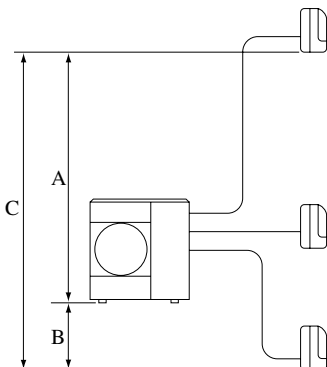

**(3) Operation data 45 ZA**

- The combinations of the indoor units is indicated by numbers. They are read as follows.  
(Example) SKM22ZA → 22 SKM40ZA → 40
- The capacity of the indoor units is shown by rooms. If this exceeds the maximum capacity of the outdoor unit, the demand capacity will be proportionally distributed.
- If units are to be combined, use the table below to make the proper selection.

**(a) Heating**

**(220/240V)**

Indoor unit combination		Heating capacity (kW)					Power consumption (W)			Running current (A)
		Room heating capacity (kW)		Total capacity (kW)			Min.	Standard	Max.	Standard
		A room	B room	Min.	Standard	Max.				
1 room	22	3.2		1.4	3.2	3.9	400	1030	1330	4.73/4.34
	25	3.4		1.4	3.4	4.0	400	1170	1390	5.37/4.92
	28	4.0		1.4	4.0	4.7	400	1350	1680	6.20/5.68
	32	4.5		1.4	4.5	5.6	400	1580	2080	7.25/6.65
	40	5.4		1.4	5.4	6.0	400	2030	2300	9.32/8.54
2 room	22+22	2.8	2.8	2.2	5.6	6.0	650	1980	2190	9.09/8.33
	22+25	2.6	3.0	2.2	5.6	6.0	650	1950	2160	8.95/8.21
	22+28	2.5	3.1	2.2	5.6	6.0	650	1900	2100	8.72/8.00
	22+32	2.3	3.3	2.2	5.6	6.0	650	1850	2050	8.49/7.79
	22+40	2.0	3.6	2.2	5.6	6.0	650	1780	1970	8.17/7.49
	25+25	2.8	2.8	2.2	5.6	6.0	650	1950	2160	8.95/8.21
	25+28	2.6	3.0	2.2	5.6	6.0	650	1880	2080	8.63/7.91
	25+32	2.5	3.1	2.2	5.6	6.0	650	1830	2030	8.40/7.70
25+40	2.2	3.4	2.2	5.6	6.0	650	1750	1940	8.03/7.37	

**(b) Cooling 45 ZA****(220/240V)**

Indoor unit combination		Cooling capacity (kW)					Power consumption (W)			Running current (A)
		Room cooling capacity (kW)		Total capacity (kW)			Min.	Standard	Max.	Standard
		A room	B room	Min.	Standard	Max.				
1 room	22	2.2		1.1	2.2	2.5	350	750	900	3.44/3.16
	25	2.5		1.1	2.5	2.8	350	900	1040	4.13/3.79
	28	2.8		1.1	2.8	3.0	350	1040	1150	4.78/4.38
	32	3.2		1.1	3.2	3.5	350	1200	1360	5.51/5.05
	40	4.0		1.1	4.0	4.5	350	1580	1850	7.25/6.65
2 room	22+22	2.2	2.2	2.0	4.4	4.7	680	1750	1950	8.03/7.37
	22+25	2.1	2.4	2.0	4.5	4.8	680	1820	2020	8.36/7.66
	22+28	2.0	2.6	2.0	4.6	4.9	680	1830	2030	8.40/7.70
	22+32	1.9	2.8	2.0	4.7	5.0	680	1840	2040	8.45/7.74
	22+40	1.7	3.1	2.0	4.8	5.1	680	1850	2050	8.49/7.79
	25+25	2.25	2.25	2.0	4.5	4.8	680	1820	2020	8.36/7.66
	25+28	2.2	2.4	2.0	4.6	4.9	680	1830	2030	8.40/7.70
	25+32	2.1	2.6	2.0	4.7	5.0	680	1840	2040	8.45/7.74
	25+40	1.8	3.0	2.0	4.8	5.1	680	1850	2050	8.49/7.79

## Range of usage & limitations

Item		Model	SCM45ZA
Indoor intake air temperature (Upper, lower limits)		Refer to the selection chart.	
Outdoor air temperature (Upper, lower limits)			
Indoor units that can be used in combination	Number of connected units	1 to 2 units	
	Total of indoor units (class kW)	6.5kW	
Total length for all rooms		Max. 30m	
Length for one indoor unit		Max. 25m	
Difference in height between indoor and outdoor units	When above outdoor unit (B)	Max. 10m	
	When below outdoor unit (A)	Max. 15m	
Difference in height between indoor units (C)		Max. 25m	
Compressor stop/start frequency	1 cycle time	6 min or more (from stop to stop or from start to start)	
	Stop time	3 min or more	
Power source voltage	Voltage fluctuation	Within $\pm 10\%$ of rated voltage	
	Voltage drop during start	Within $\pm 15\%$ of rated voltage	
	Interval unbalance	Within $\pm 3\%$ of rated voltage	

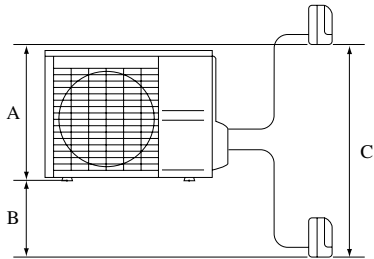

**(3) Operation data 68 YA**

- The combinations of the indoor units is indicated by numbers. They are read as follows.

(Example) SKM22YA → 22 SKM40YA → 40

- The capacity of the indoor units is shown by rooms. If this exceeds the maximum capacity of the outdoor unit, the demand capacity will be proportionally distributed.
- If units are to be combined, use the table below to make the proper selection.

**◆Cooling 68 YA**

Indoor unit combination		Cooling capacity (kW)						Power consumption (W)			Standard current (A)		
		Room Cooling capacity (kW)			Total capacity (kW)			Min.	Standard	Max.	220V	230V	240V
		A room	B room	C room	Min.	Standard	Max.						
1 room	22	2.2			1.8	2.2	2.5	500	600	700	3.2	3.1	3.0
	25	2.5			1.8	2.5	2.8	500	750	870	3.9	3.9	3.7
	40	4.0			2.6	4.0	4.5	1,050	1,500	1,750	7.9	7.7	7.5
2 room	22+22	2.2	2.2		2.8	4.4	5.0	1,200	1,700	2,010	8.9	8.7	8.5
	22+25	2.2	2.5		2.8	4.7	5.3	1,200	1,850	2,170	9.7	9.5	9.2
	22+40	2.1	3.9		2.8	6.0	6.2	1,200	2,600	2,810	13.7	13.4	13.0
	25+25	2.5	2.5		2.8	5.0	5.6	1,200	2,000	2,330	10.5	10.3	10.0
	25+40	2.3	3.7		2.8	6.0	6.2	1,200	2,710	2,930	14.3	13.9	13.5
	40+40	3.2	3.2		2.8	6.4	6.6	1,200	2,960	3,200	15.6	15.2	14.8
3 room	22+22+22	2.03	2.03	2.03	4.0	6.1	6.3	1,650	2,730	2,950	14.4	14.0	13.6
	22+22+25	1.9	1.9	2.3	4.0	6.1	6.3	1,650	2,780	3,010	14.6	14.3	13.9
	22+22+40	1.7	1.7	3.1	4.0	6.5	6.7	1,650	3,030	3,280	15.9	15.6	15.1
	22+25+25	1.8	2.2	2.2	4.0	6.2	6.4	1,650	2,830	3,060	14.9	14.5	14.1
	22+25+40	1.7	1.9	3.0	4.0	6.6	6.8	1,650	3,080	3,330	16.2	15.8	15.4
	22+40+40	1.5	2.6	2.6	4.0	6.7	6.9	1,650	3,170	3,380	16.7	16.3	15.8
	25+25+25	2.1	2.1	2.1	4.0	6.3	6.5	1,650	2,880	3,110	15.2	14.8	14.4
	25+25+40	1.9	1.9	2.9	4.0	6.7	6.9	1,650	3,130	3,380	16.5	16.1	15.6
	25+40+40	1.5	2.6	2.6	4.0	6.7	6.9	1,650	3,170	3,380	16.7	16.3	15.8
	40+40+40	2.27	2.27	2.27	4.0	6.8	7.0	1,650	3,230	3,400	17.0	16.6	16.1



## Range of usage & limitations

Item		Model	SCM68YA
Indoor intake air temperature (Upper, lower limits)		Refer to the selection chart.	
Outdoor air temperature (Upper, lower limits)			
Indoor units that can be used in combination	Number of connected units	1 to 3 units	
	Total of indoor Units (class kW)	12.0kW	
Total length for all rooms		Max. 40m	
Length for one indoor unit		Max. 25m	
Difference in height between indoor and outdoor units	When above outdoor unit (B)	Max. 10m	
	When below outdoor unit (A)	Max. 15m	
Difference in height between indoor units (C)		Max. 25m	
Compressor stop/start frequency	1 cycle time	6 min or more (from stop to stop or from start to start)	
	Stop time	3 min or more	
Power source voltage	Voltage fluctuation	Within $\pm 10\%$ of rated voltage	
	Voltage drop during start	Within $\pm 15\%$ of rated voltage	
	Interval unbalance	Within $\pm 3\%$ of rated voltage	

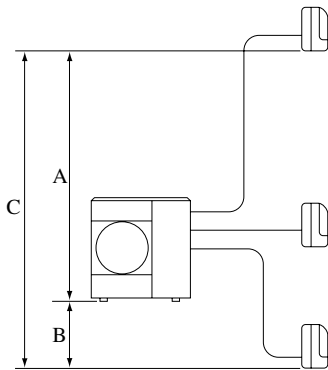

**(3) Operation data 45 YA**

- The combinations of the indoor units is indicated by numbers. They are read as follows.  
(Example) SKM22YA → 22 SKM40YA → 40
- The capacity of the indoor units is shown by rooms. If this exceeds the maximum capacity of the outdoor unit, the demand capacity will be proportionally distributed.
- If units are to be combined, use the table below to make the proper selection.

◆ Cooling

(220/240V)

Indoor unit combination		Cooling capacity (kW)					Power consumption (W)			Running current (A)
		Room cooling capacity (kW)		Total capacity (kW)			Min.	Standard	Max.	Standard
		A room	B room	Min.	Standard	Max.				
1 room	22	2.2		1.1	2.2	2.5	350	750	900	3.44/3.16
	25	2.5		1.1	2.5	2.8	350	900	1040	4.13/3.79
	40	4.0		1.1	4.0	4.5	350	1580	1850	7.25/6.65
2 room	22+22	2.2	2.2	2.0	4.4	4.7	680	1750	1950	8.03/7.37
	22+25	2.1	2.4	2.0	4.5	4.8	680	1820	2020	8.36/7.66
	22+40	1.7	3.1	2.0	4.8	5.1	680	1850	2050	8.49/7.79
	25+25	2.25	2.25	2.0	4.5	4.8	680	1820	2020	8.36/7.66
	25+40	1.8	3.0	2.0	4.8	5.1	680	1850	2050	8.49/7.79

## Range of usage & limitations

Item		Model	SCM45YA
Indoor intake air temperature (Upper, lower limits)		Refer to the selection chart.	
Outdoor air temperature (Upper, lower limits)			
Indoor units that can be used in combination	Number of connected units	1 to 2 units	
	Total of indoor units (class kW)	6.5kW	
Total length for all rooms		Max. 30m	
Length for one indoor unit		Max. 25m	
Difference in height between indoor and outdoor units	When above outdoor unit (B)	Max. 10m	
	When below outdoor unit (A)	Max. 15m	
Difference in height between indoor units (C)		Max. 25m	
Compressor stop/start frequency	1 cycle time	6 min or more (from stop to stop or from start to start)	
	Stop time	3 min or more	
Power source voltage	Voltage fluctuation	Within $\pm 10\%$ of rated voltage	
	Voltage drop during start	Within $\pm 15\%$ of rated voltage	
	Interval unbalance	Within $\pm 3\%$ of rated voltage	

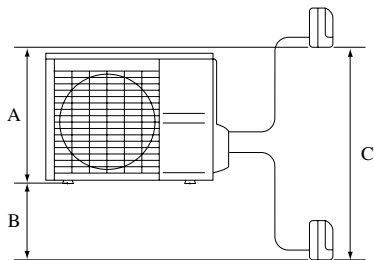

# Exterior dimensions

## (1) Indoor unit

Models SKM22ZA, 25ZA

Unit: mm

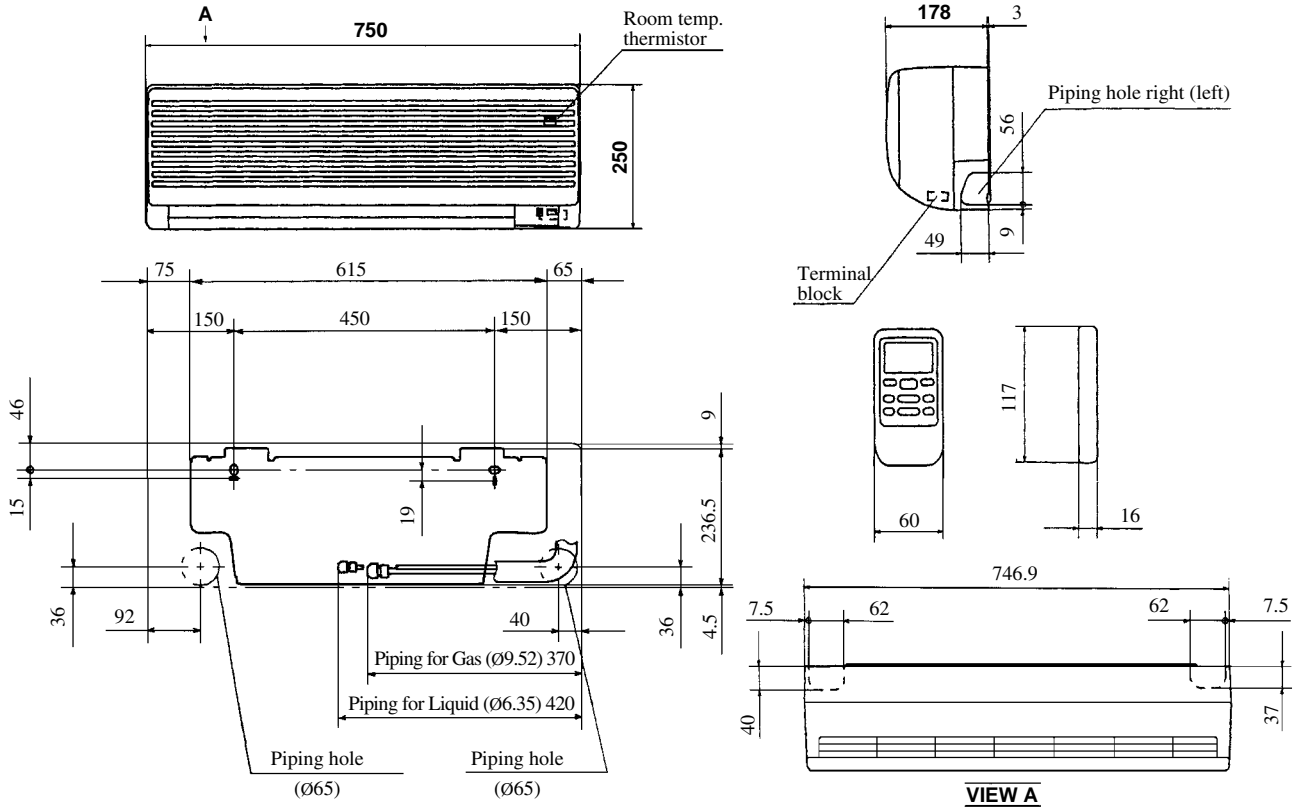

Model SKM28ZA

Unit: mm

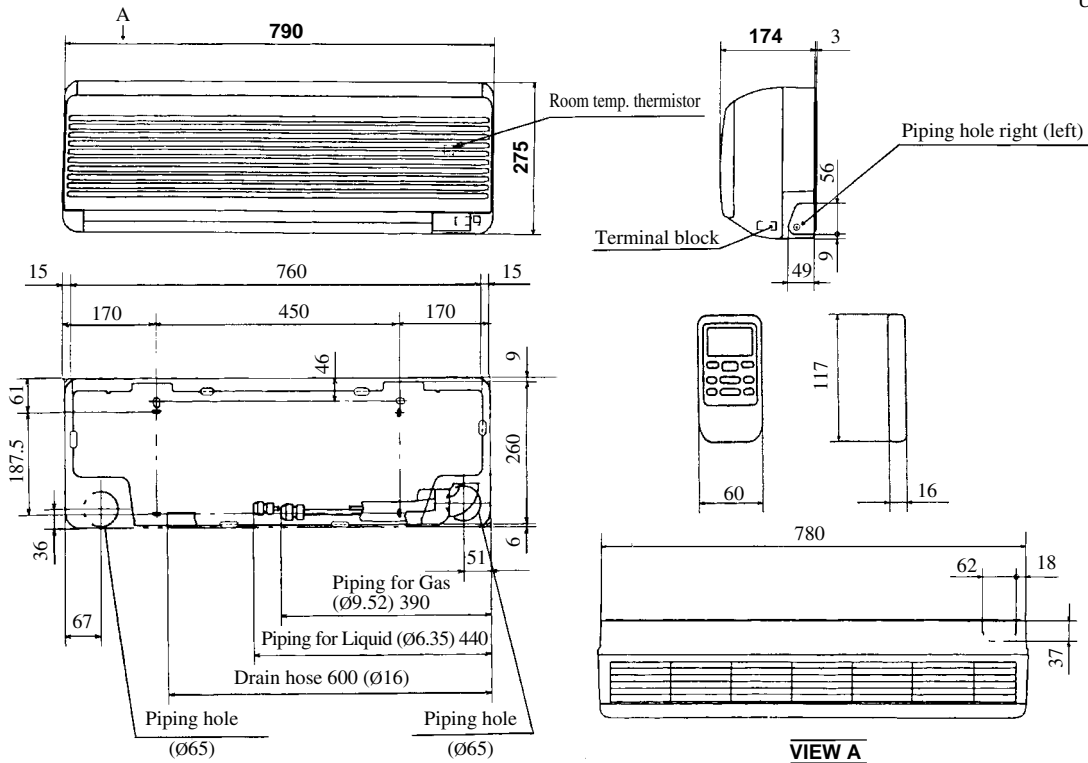

**Models SKM32ZA, 40ZA**

Unit: mm

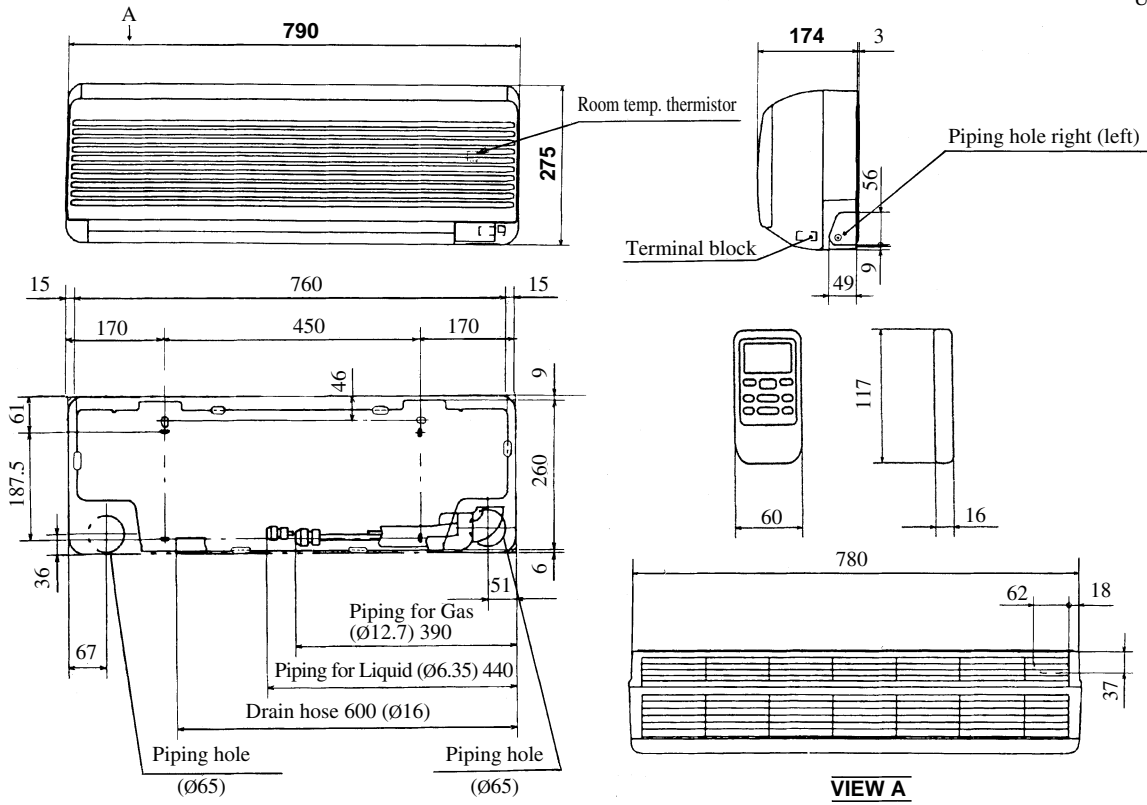

**Model SKM50ZA**

Unit: mm

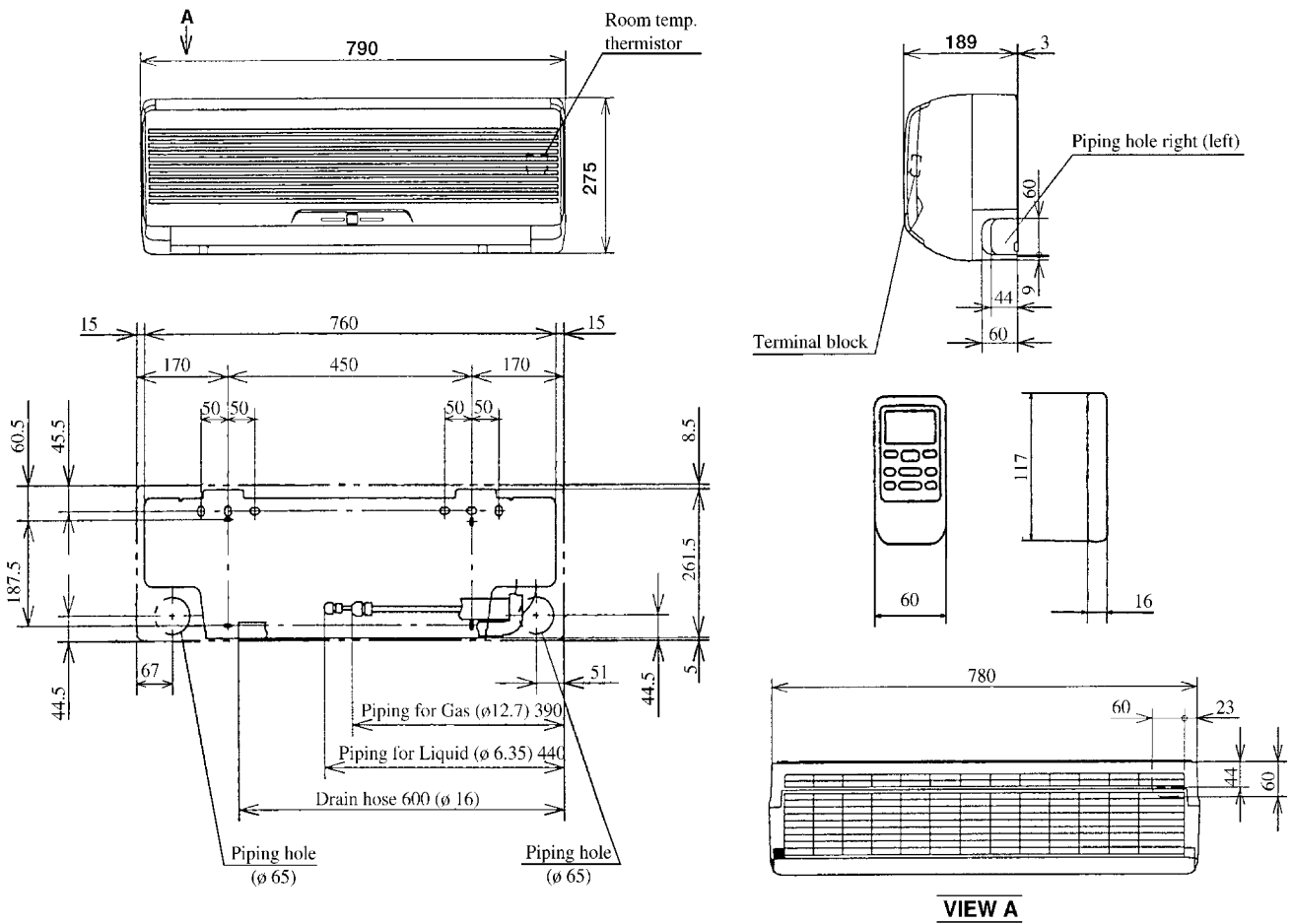

**Model SRRM40ZA**

Unit: mm

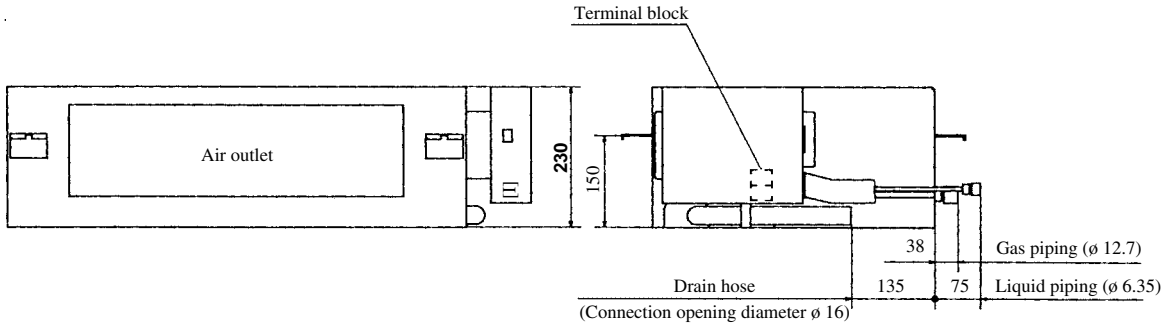
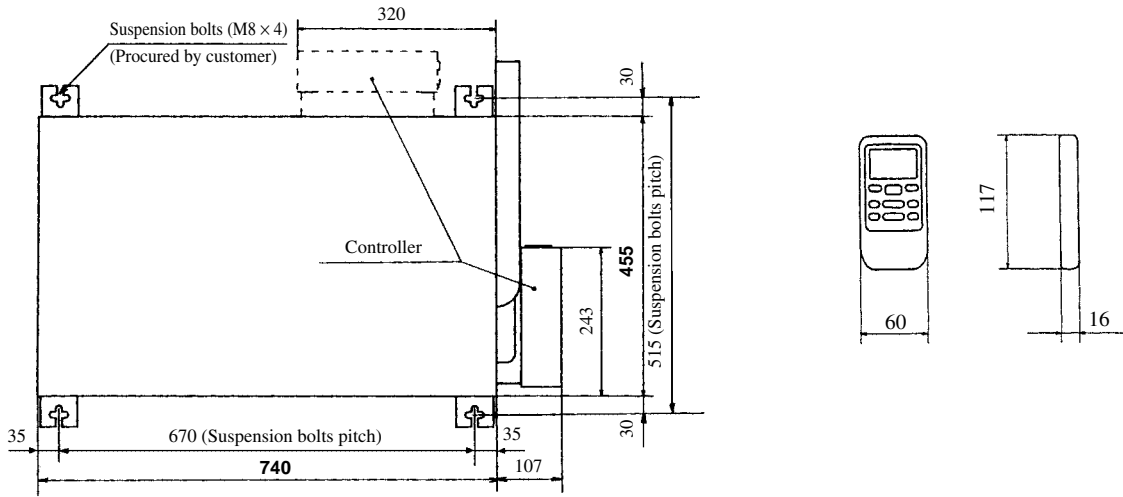

**• Details of air outlet**

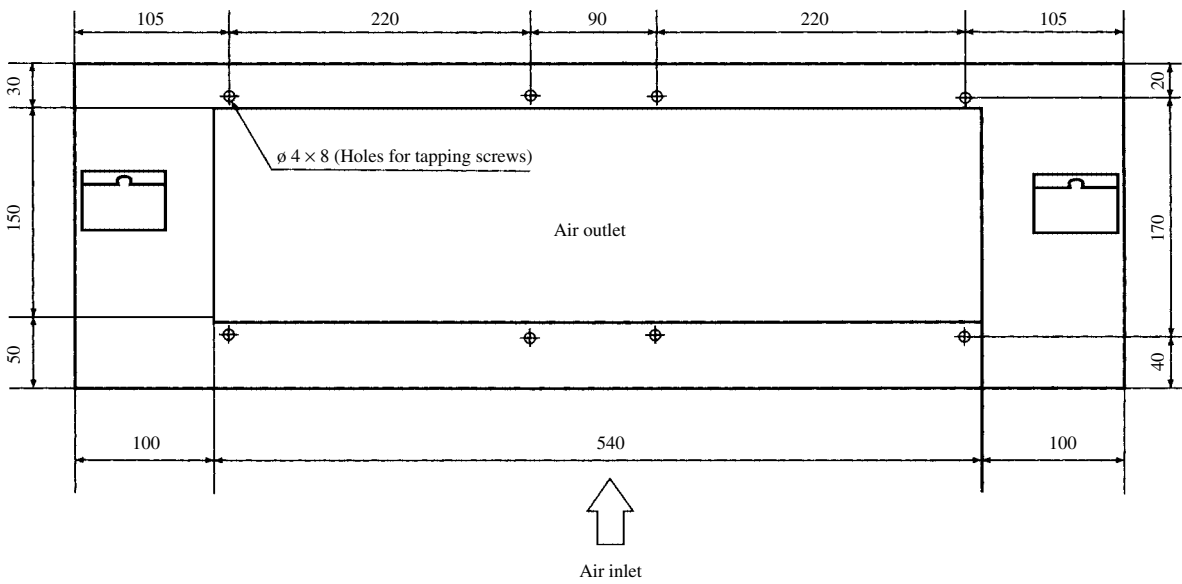

(1) Indoor unit  
Models SKM22YA, 25YA

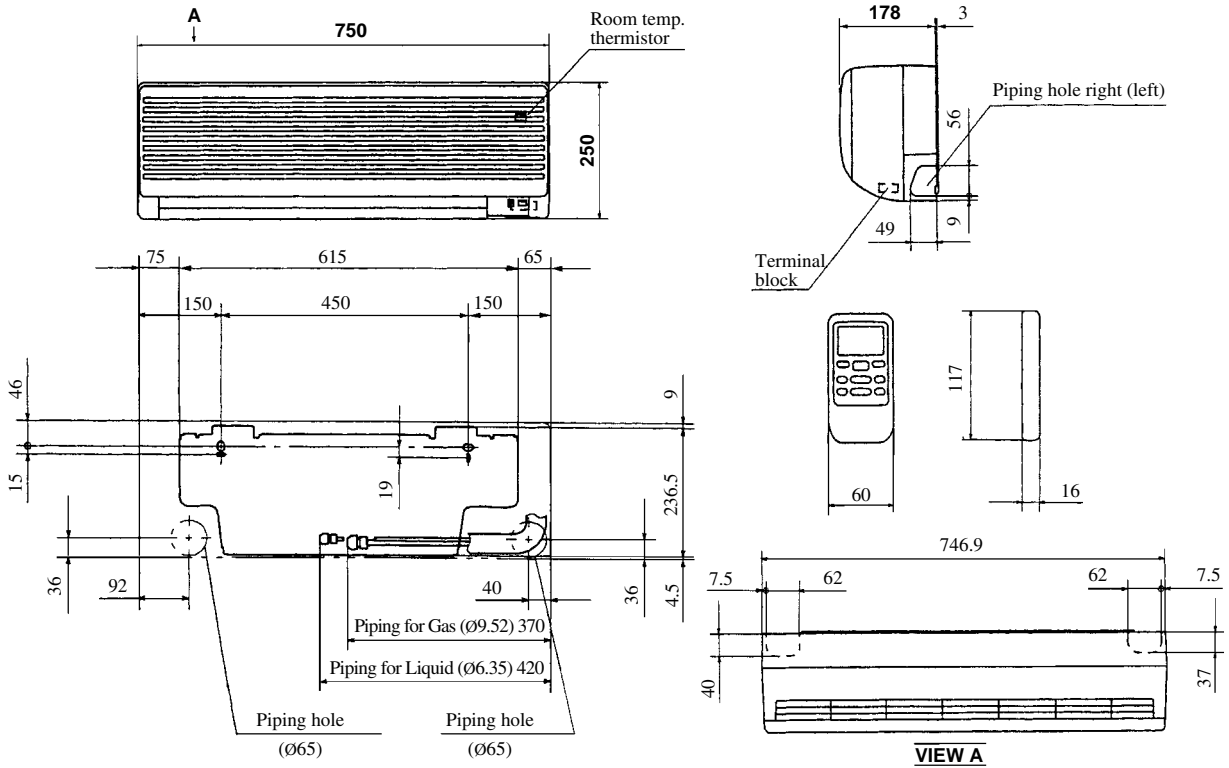

Model SKM40YA

Unit: mm

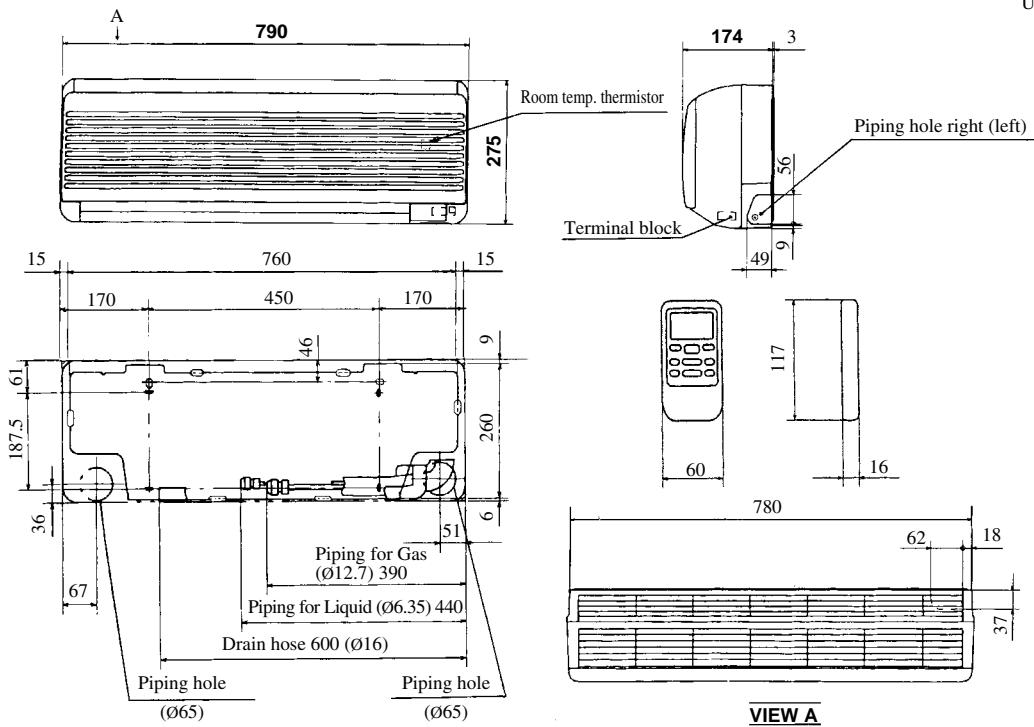

(2) Outdoor unit  
Model SCM80ZA

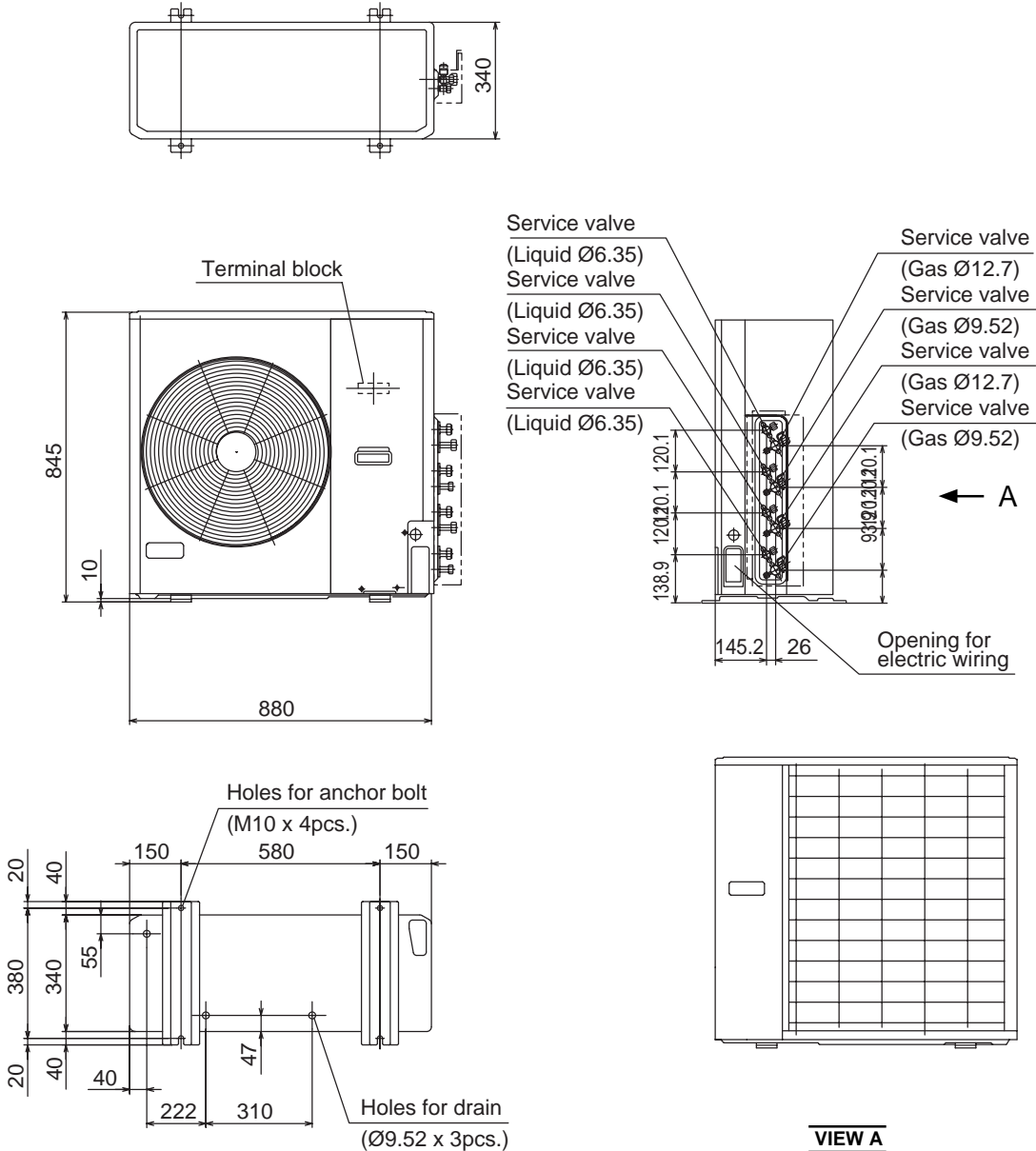

Required space for maintenance and air flow

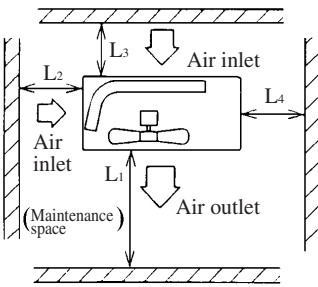

Minimum allowable space to the obstacles

Unit:mm

Mark	Installation type		
	I	II	III
L <sub>1</sub>	Open	Open	500
L <sub>2</sub>	300	50	Open
L <sub>3</sub>	100	150	100
L <sub>4</sub>	200	200	200

- Notes
- (1) Avoid the location where four sides are entirely surrounded by walls.
  - (2) Fix the unit by anchor bolts without fail. Restrict the protrusion length of anchor bolt to 15 mm and under.
  - (3) When strong wind blows against the unit, direct the discharge port at a right angle to the wind direction.
  - (4) Secure the space of 1 m and over at the top of unit.
  - (5) Make the height of obstruction wall in front of discharge port lower than the height of unit.



**(2) Outdoor unit  
Model SCM68ZA**

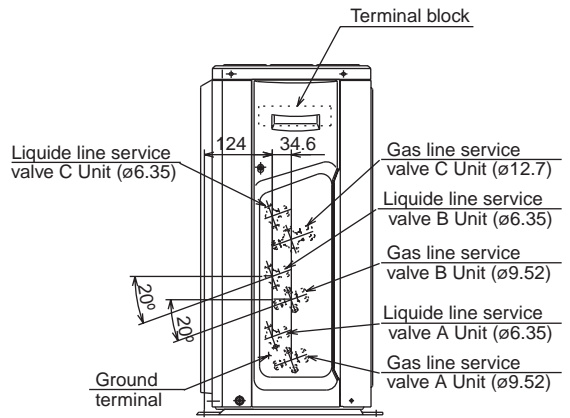
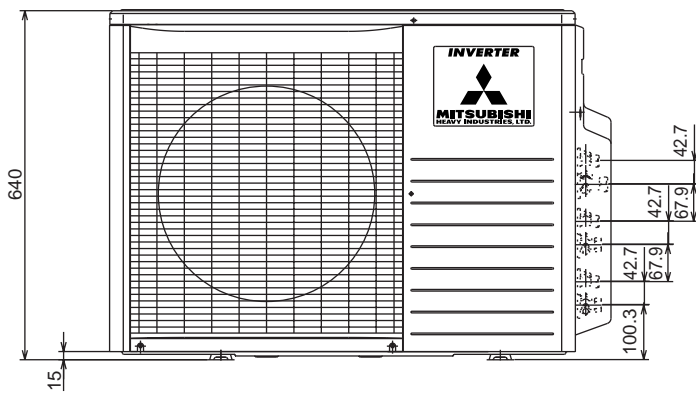
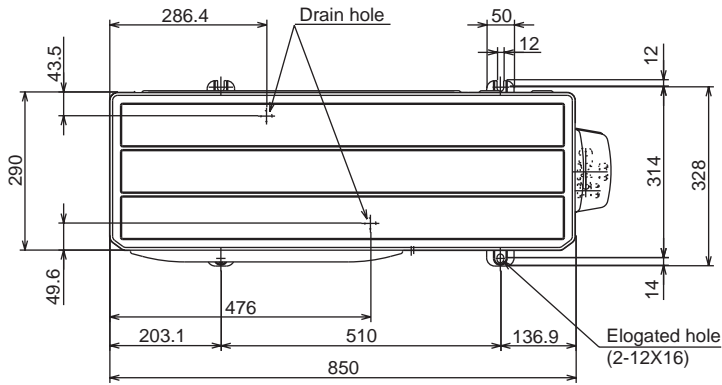

**Model SCM45ZA**

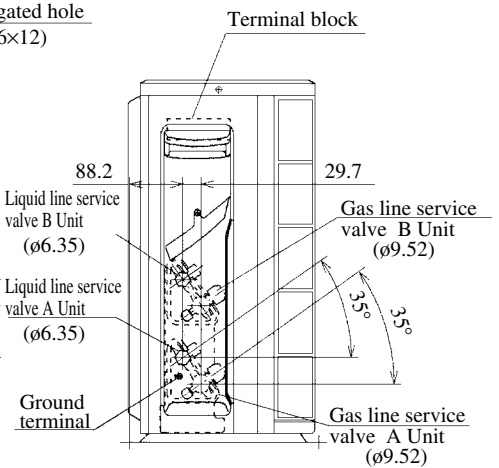
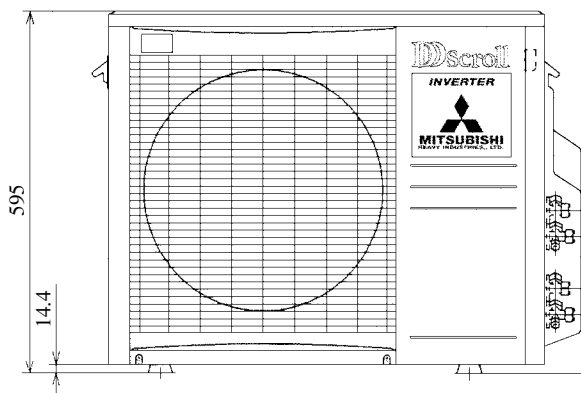
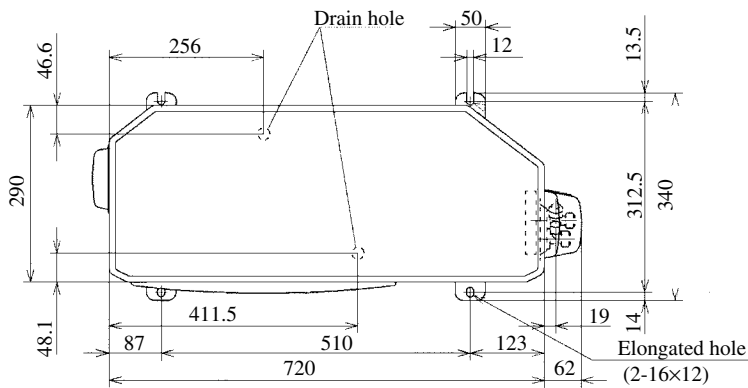



# Piping system

Model SCM80ZA

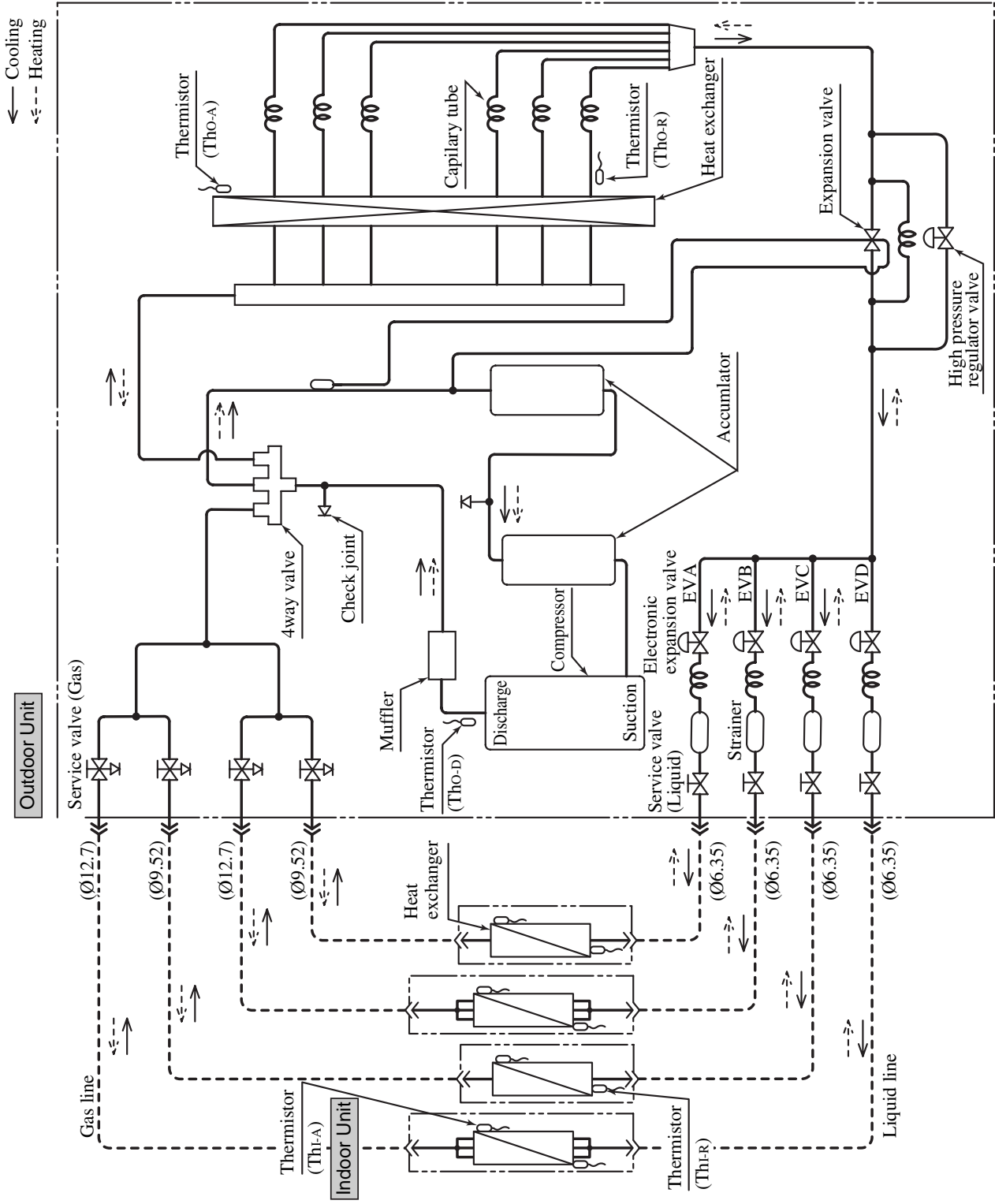

**Model SCM68YA**

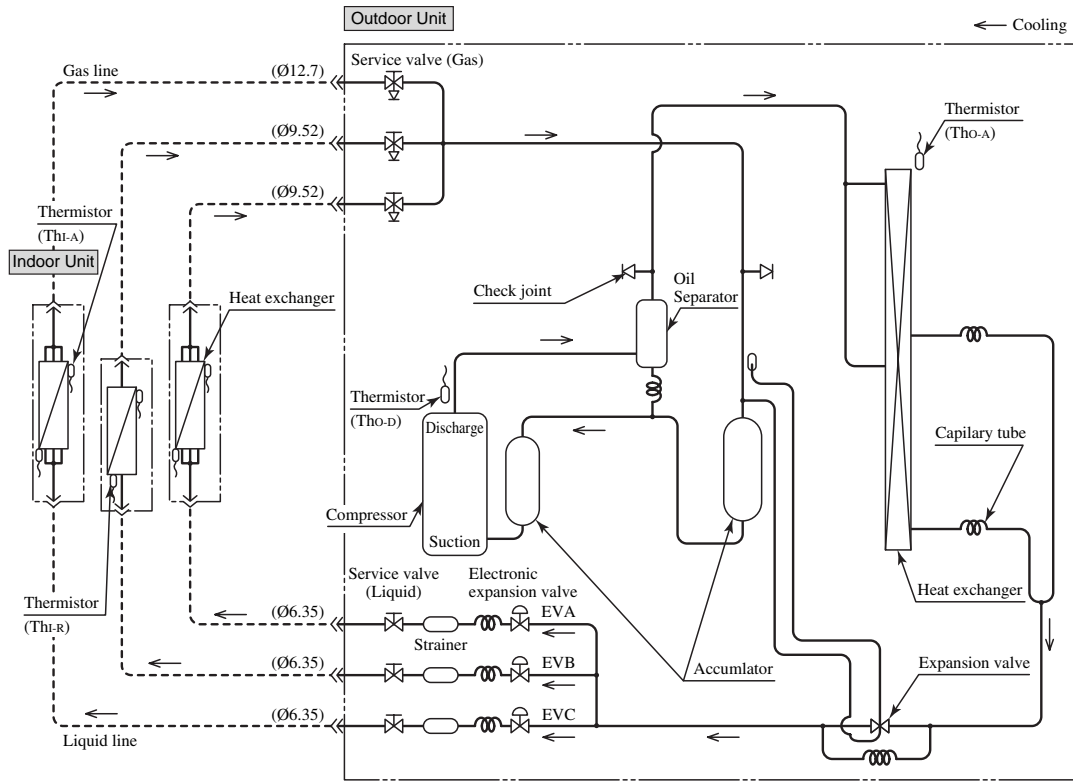

**Model SCM45YA**

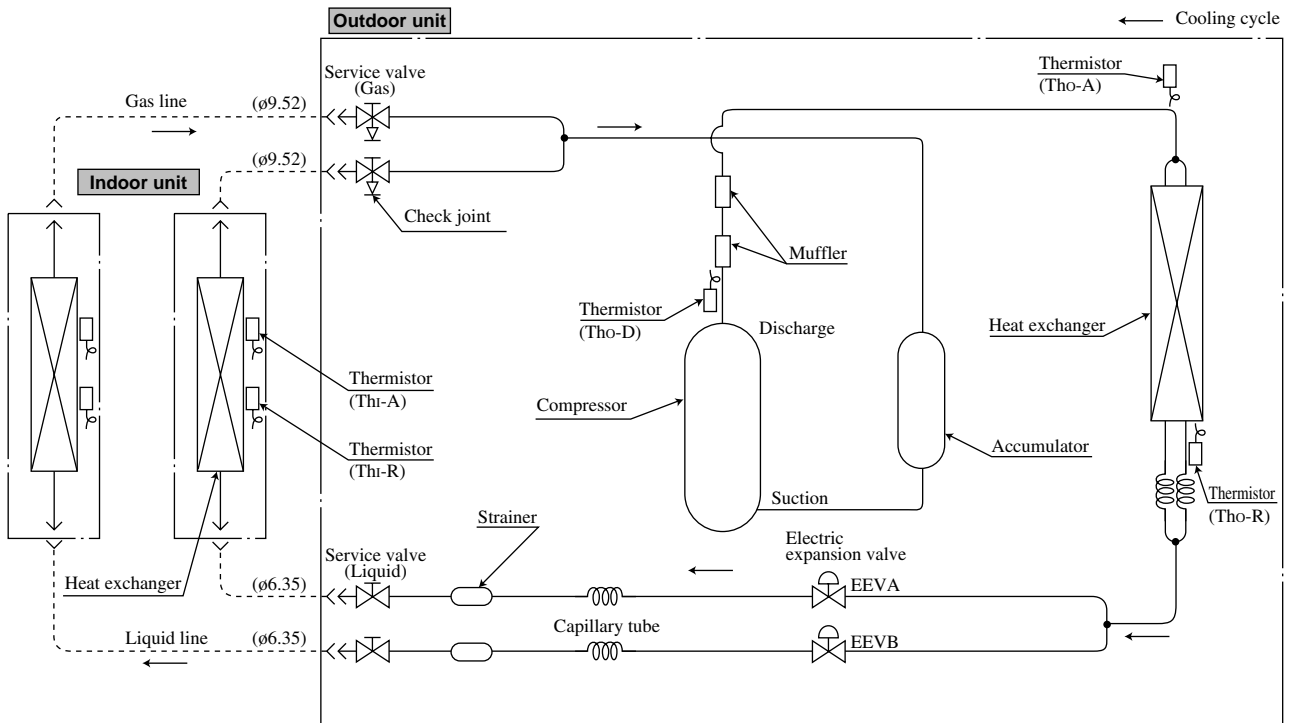

**Model SCM68ZA**

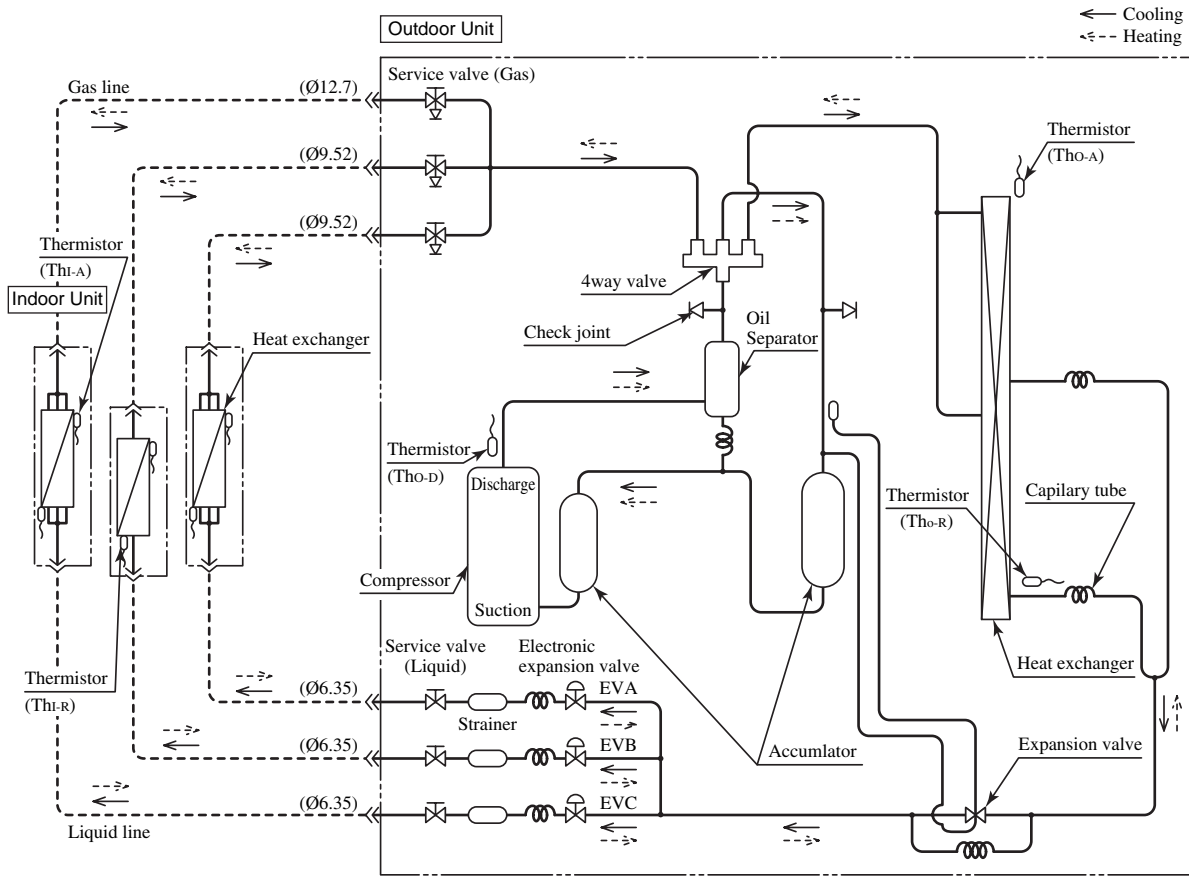

**Model SCM45ZA**

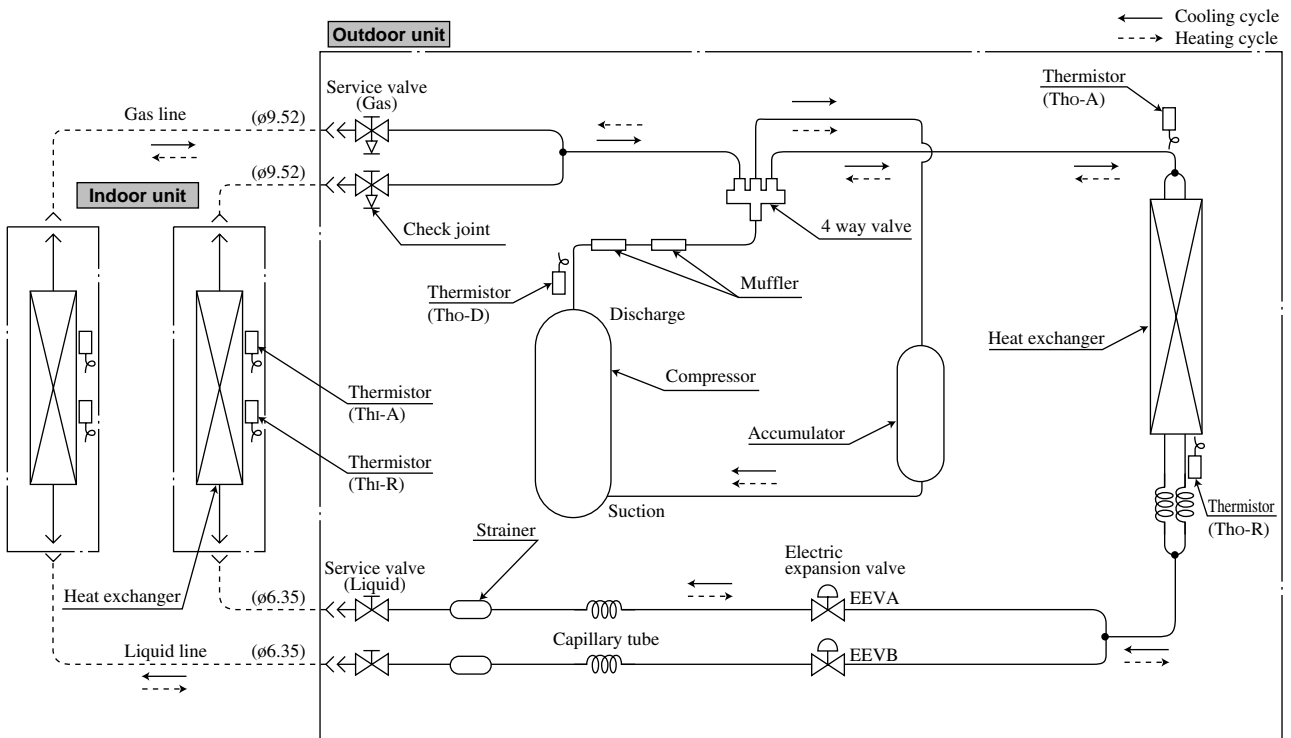

## Selection chart

Correct the cooling and heating capacity in accordance with the conditions as follows. The net cooling and heating capacity can be obtained in the following way.

**Net capacity = Capacity shown on specification × Correction factors as follows.**

### (1) Coefficient of cooling and heating capacity in relation to temperatures

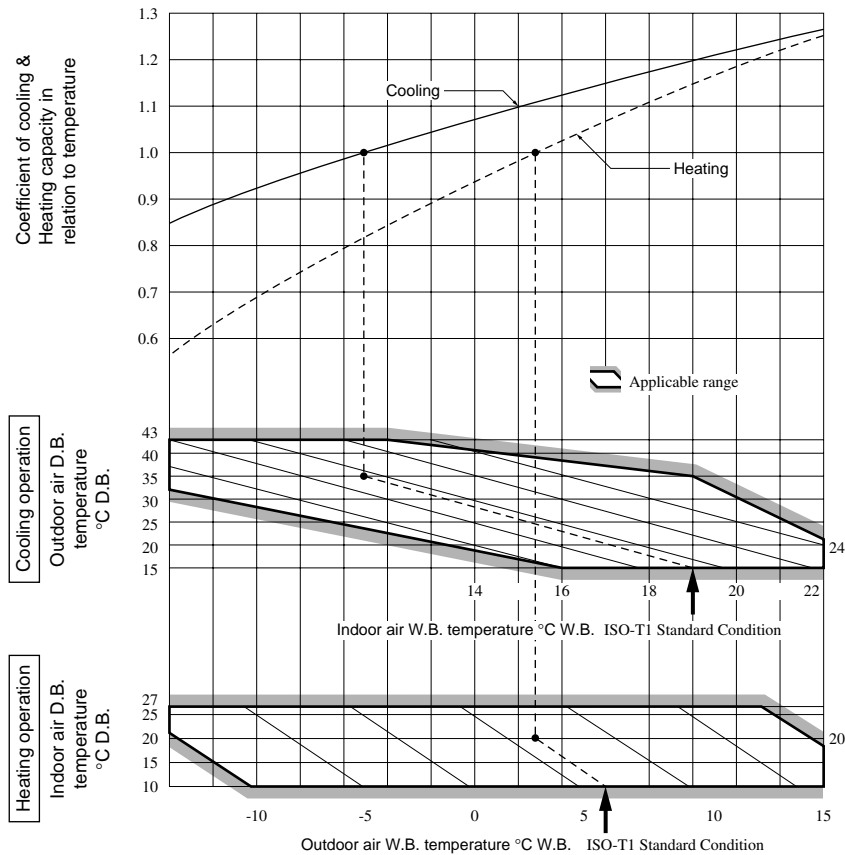

### (2) Correction of cooling and heating capacity in relation to one way length of refrigerant piping

It is necessary to correct the cooling and heating capacity in relation to the one way piping length between the indoor and outdoor units.

Piping length [m]	7	10	15	20	25
Cooling	1.0	0.99	0.975	0.965	0.95
Heating	1.0	1.0	1.0	1.0	1.0

### (3) Correction relative to frosting on outdoor heat exchanger during heating

In additions to the foregoing corrections (1), (2) the heating capacity needs to be adjusted also with respect to the frosting on the outdoor heat exchanger.

Air inlet temperature of outdoor unit in °CWB	-10	-9	-7	-5	-3	-1	1	3	5
Adjustment coefficient	0.95	0.94	0.93	0.91	0.88	0.86	0.87	0.92	1.00

# ELECTRICAL DATA

## Meaning of marks

### • Outdoor Unit

Symbol	Parts name	Symbol	Parts name
CM	Compressor motor	EEVA ~ D	Electric expansion valve
C	Capacitor	20S	4 way valve (coil)
FM <sub>0</sub>	Fan motor	Tho-A	Thermistor (outdoor air temp.)
Re	Reactor	Tho-R	Thermistor (outdoor H.X temp.)
SA	Serge absorber	Tho-D	Thermistor (discharge temp.)
CT	Current sensor	LED5	Warning lamp (Red)
DS1, DS2	Diode stack	LED1 ~ 4	Serial signal lamp (Green)
NF	Noise filter	51C	Motor protector for CM
52X <sub>s</sub>	Auxiliary relay		

### • Indoor Unit

Symbol	Parts name	Symbol	Parts name
FM <sub>i</sub>	Fan motor	Q	Fan motor control triac
CF <sub>i</sub>	Capacitor (for FM <sub>i</sub> )	F	Fuse
SM	Flap motor	Thi-A	Thermistor (room temp.)
Tr	Transformer	Thi-R	Thermistor (indoor H.X temp.)
ZNR	Varistor	52X <sub>1-5</sub>	Auxiliary relay
DM	Drain motor	Thi-H	Thermistor (humidity)
FS	Float switch		

## (1) Indoor unit

Models SKM22ZA, 25ZA, 28ZA, 32ZA, 40ZA

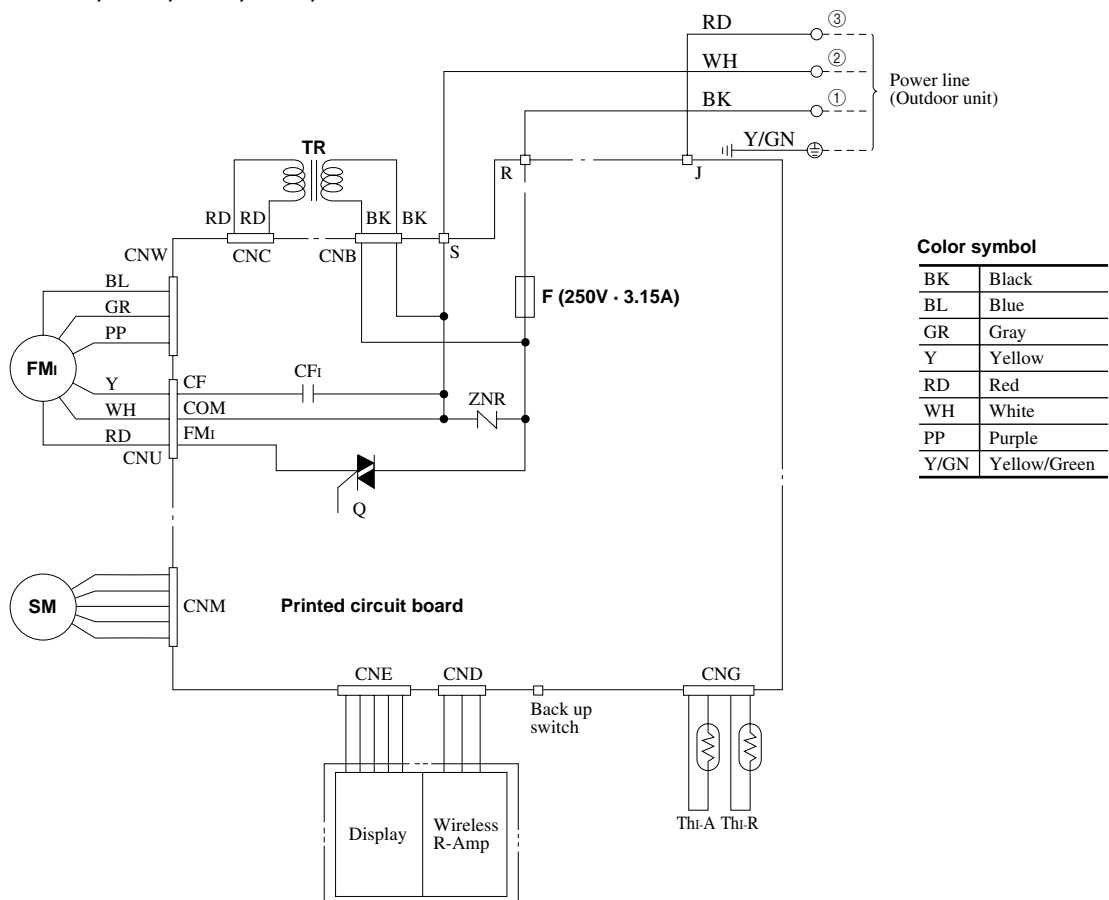

**Model SKM50ZA**

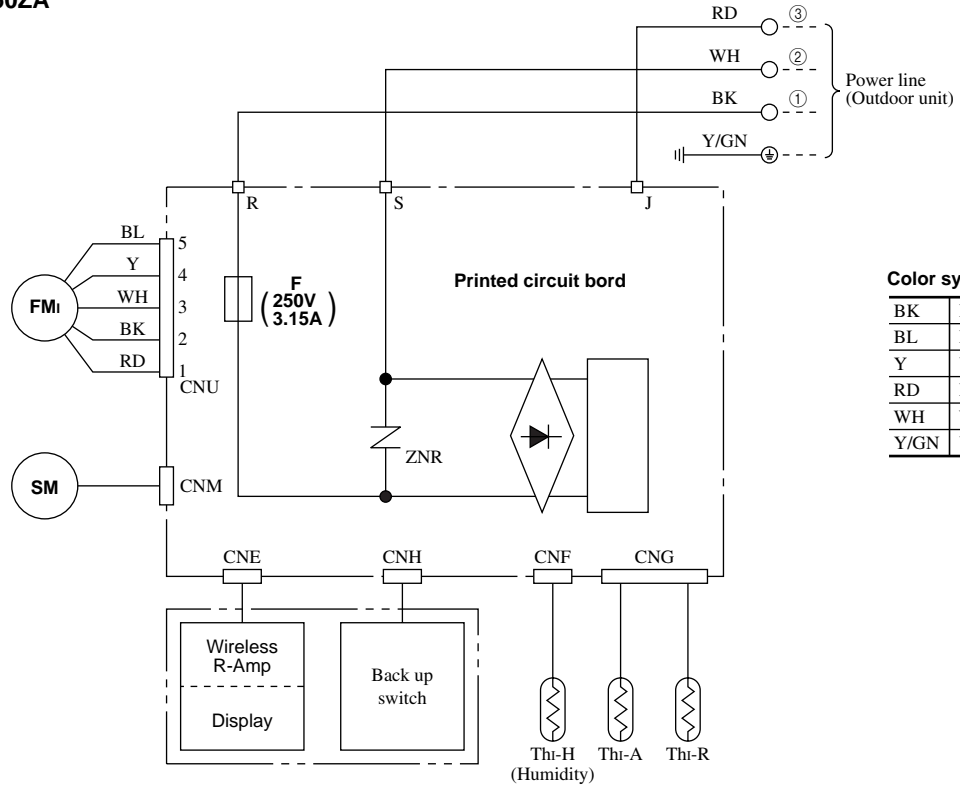

**Color symbol**

BK	Black
BL	Blue
Y	Yellow
RD	Red
WH	White
Y/GN	Yellow/Green

**Model SRRM40ZA**

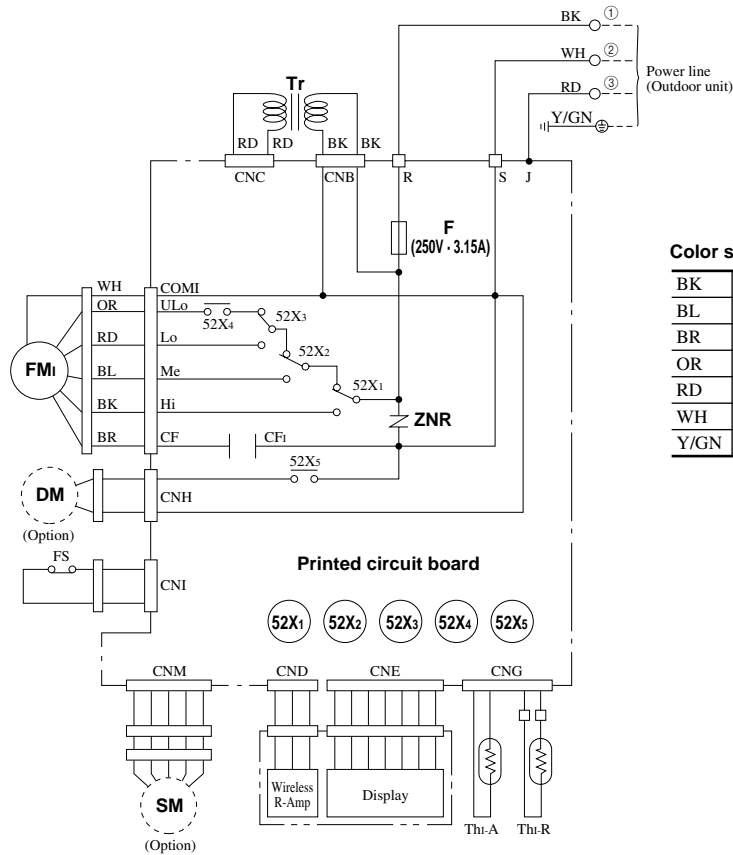

**Color symbol**

BK	Black
BL	Blue
BR	Brown
OR	Orange
RD	Red
WH	White
Y/GN	Yellow/Green



( Indoor unit  
 Models SKM22YA, 25YA, 40YA

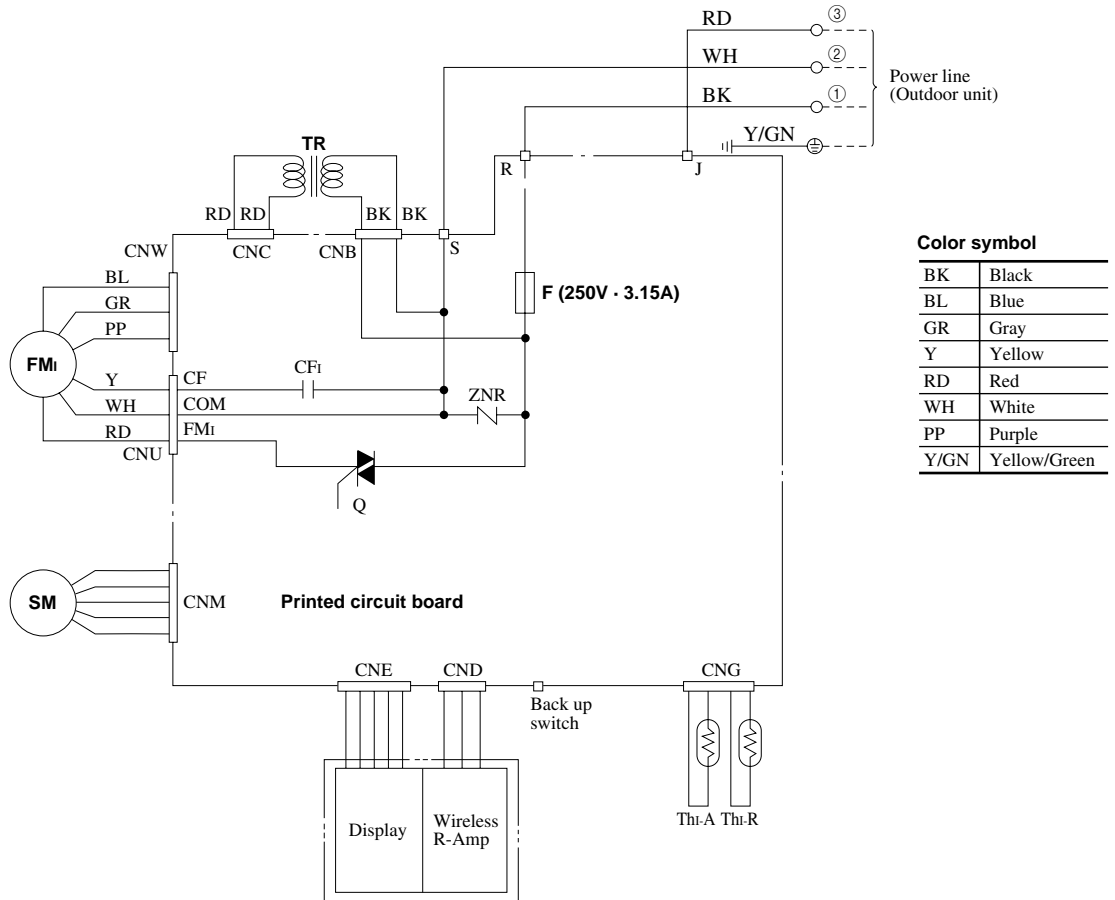

**(2) Outdoor unit**  
**Model SCM80ZA**

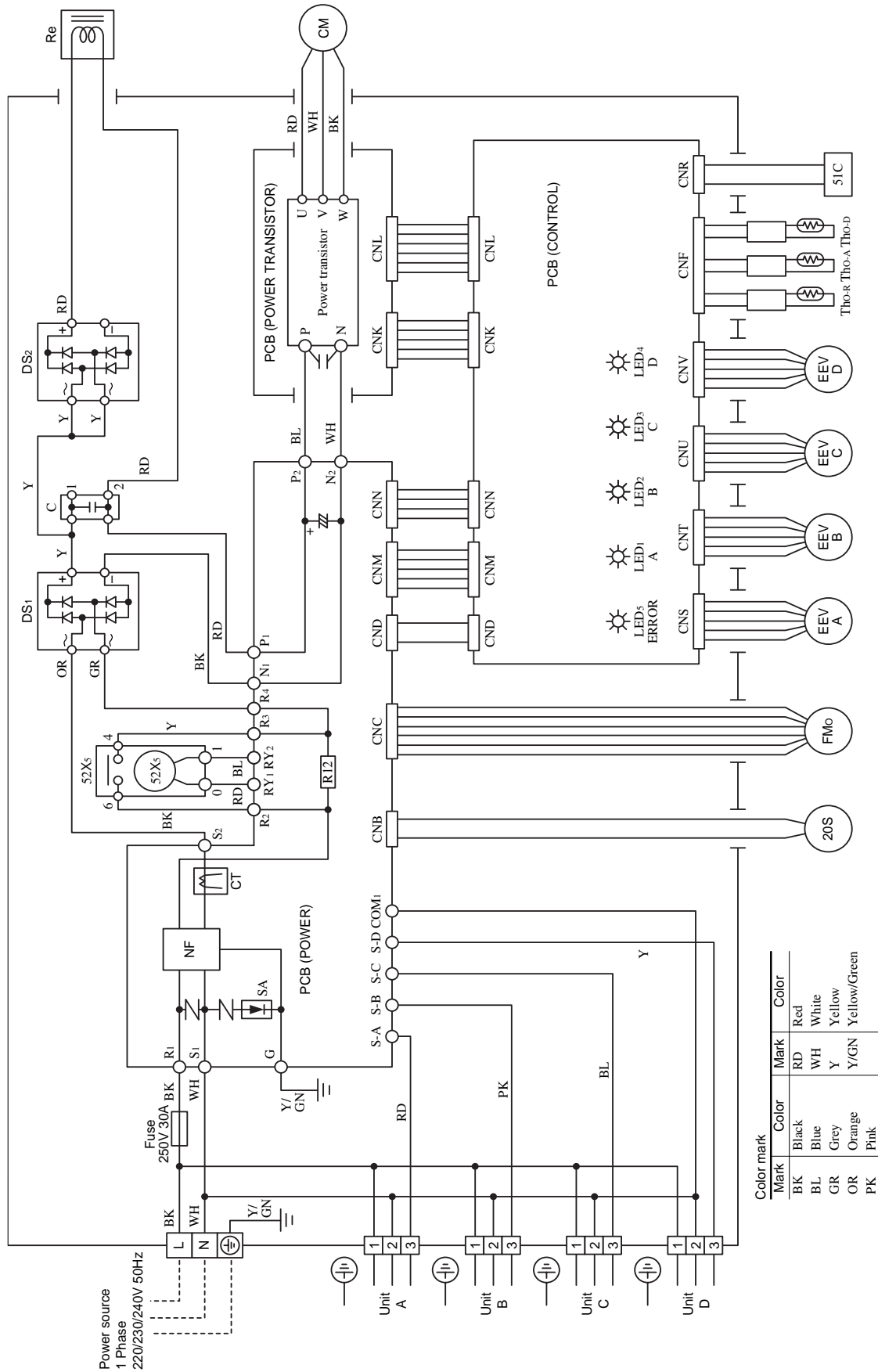

**(2) Outdoor unit  
Model SCM68ZA**

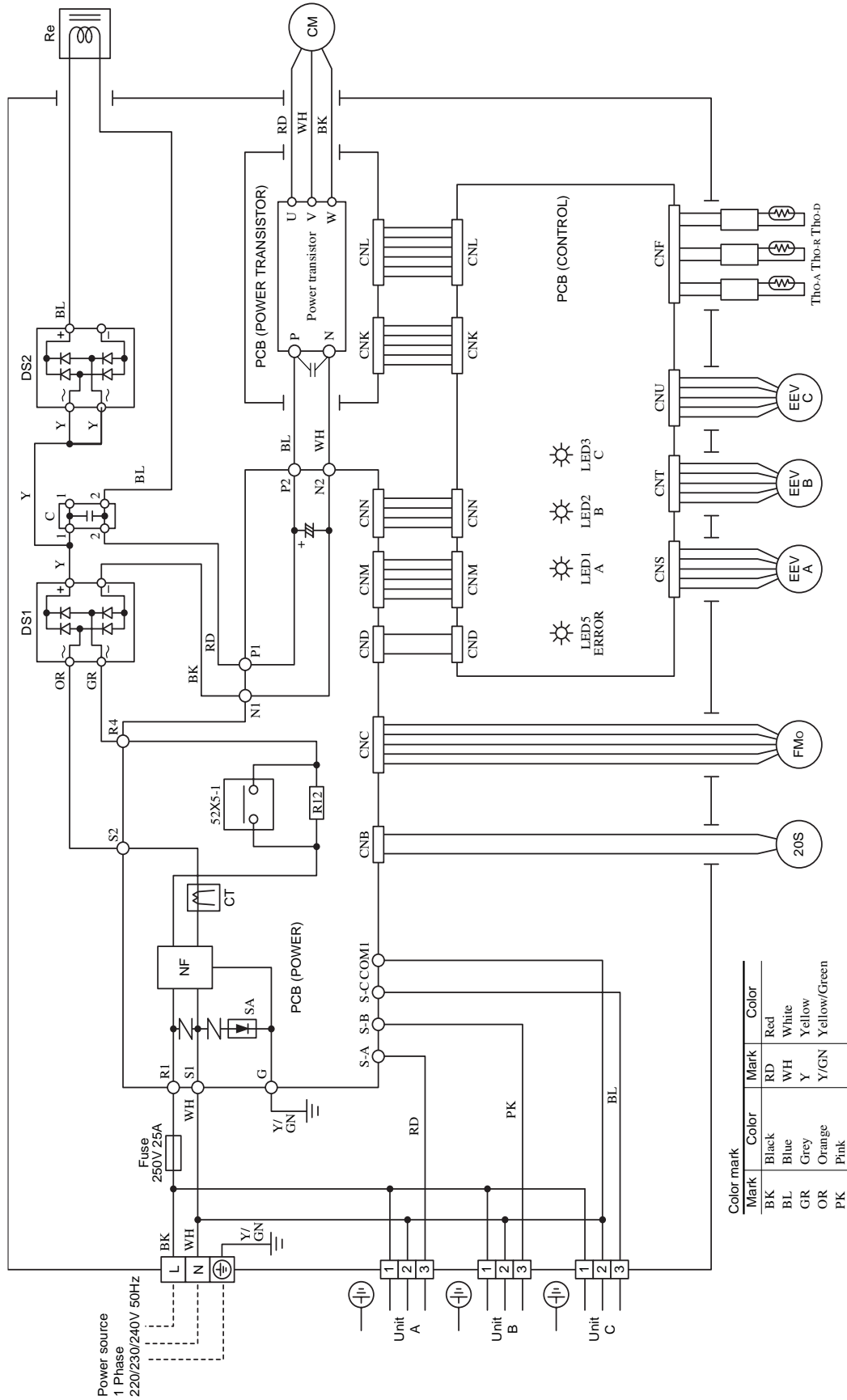

Color mark

Mark	Color	Mark	Color
BK	Black	RD	Red
BL	Blue	WH	White
GR	Grey	Y	Yellow
OR	Orange	Y/GN	Yellow/Green
PK	Pink		

**(2) Outdoor unit**  
**Model SCM68YA**

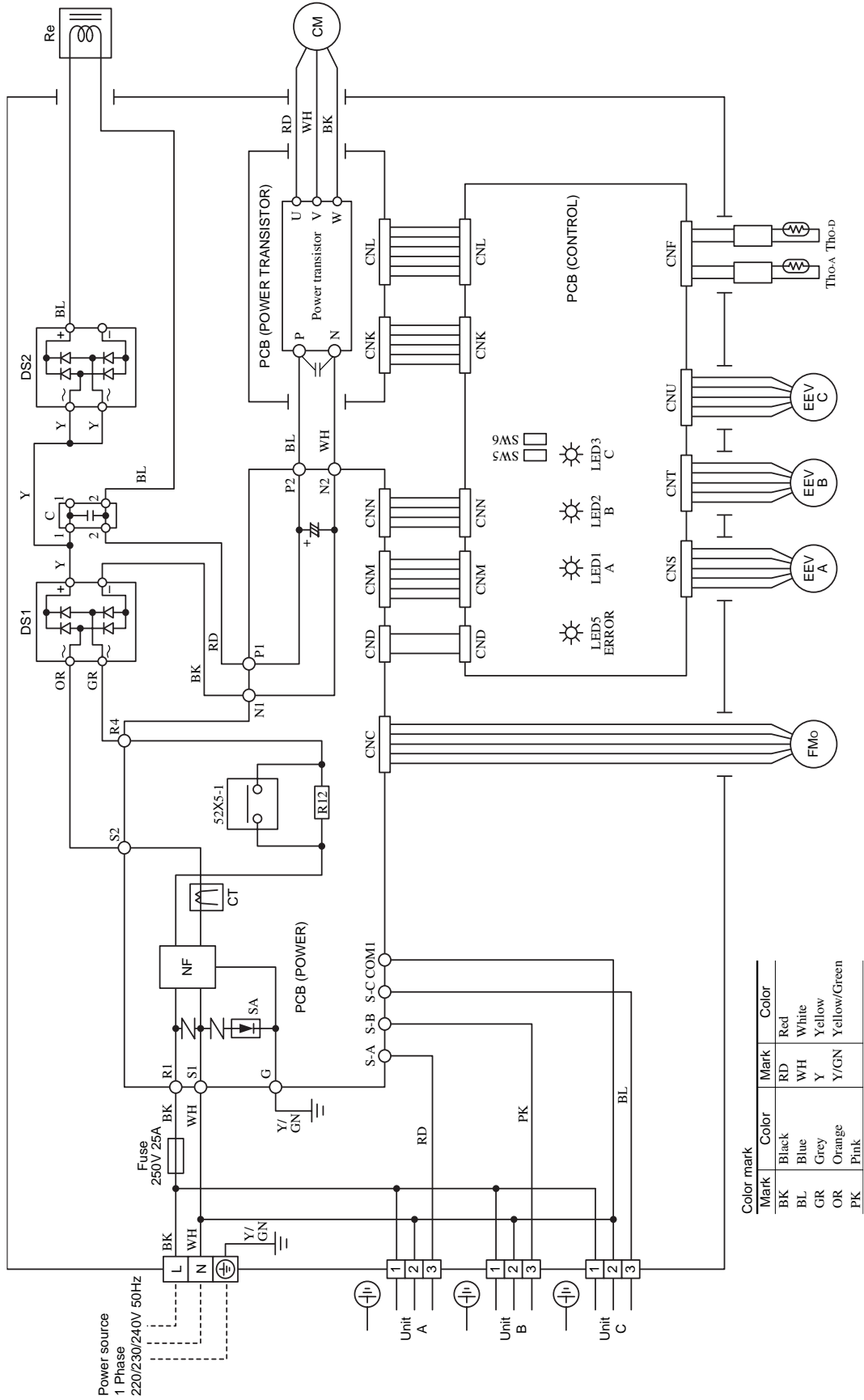

**(2) Outdoor unit  
Model SCM45ZA**

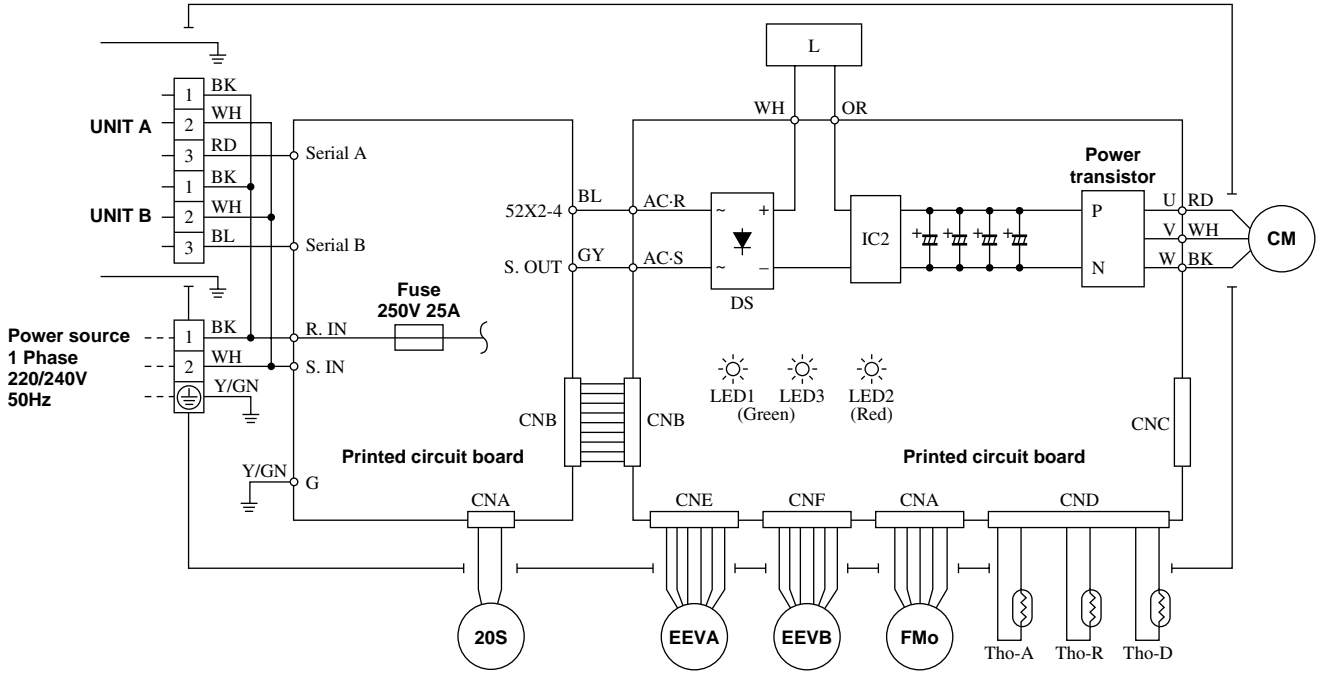

**Color symbol**

BK	Black
BL	Blue
GY	Gray
RD	Red
WH	White
OR	Orange
Y/GN	Yellow/Green

**Model SCM45YA**

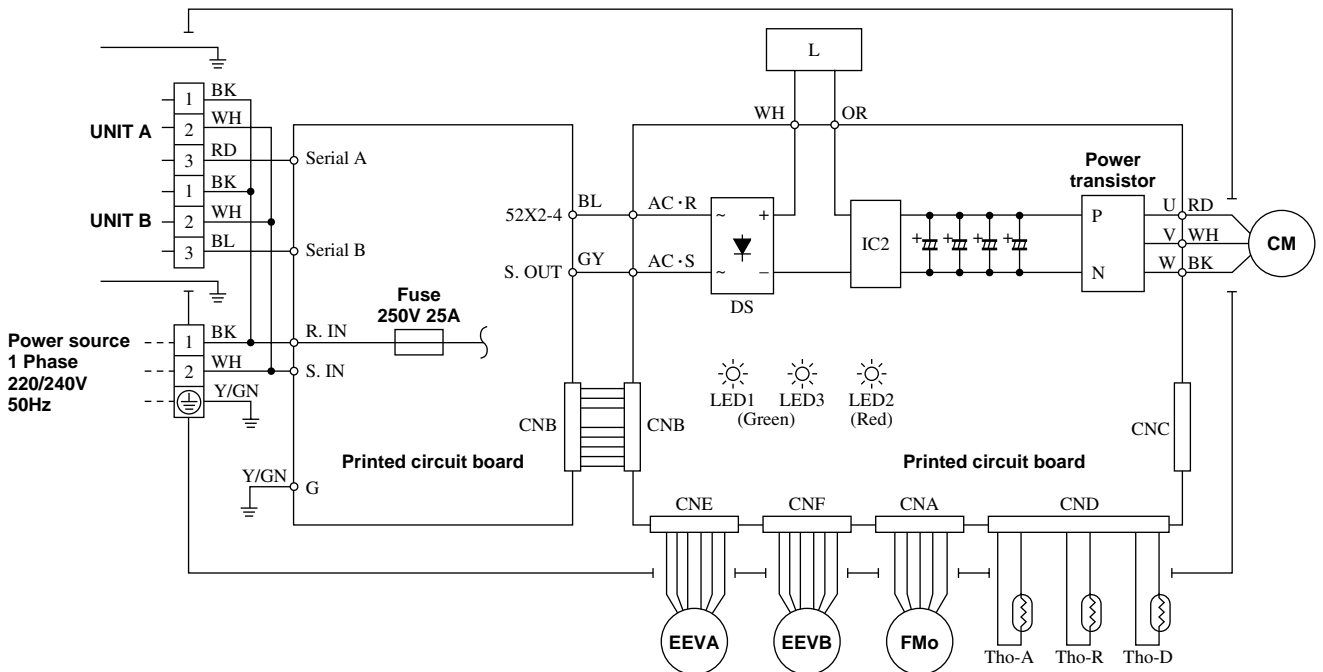

# OUTLINE OF OPERATION CONTROL BY MICROCOMPUTER

## (1) Remote Controller

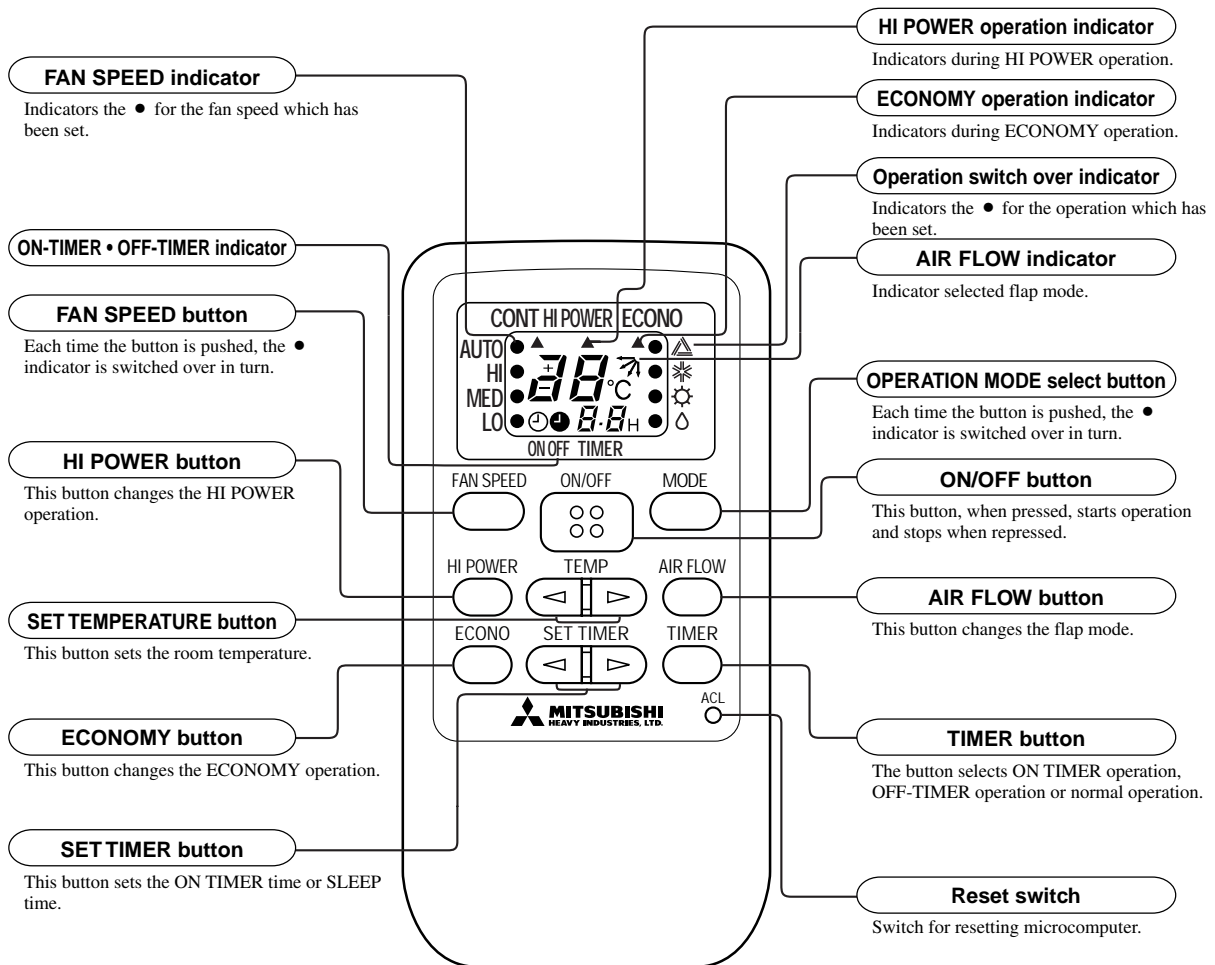

- Above figure shows all indications for the purpose of explanation, but practically only the pertinent parts are indicated.

## (2) Indoor unit indicator

- SKM22, 25 models

- SKM28, 32, 40 models

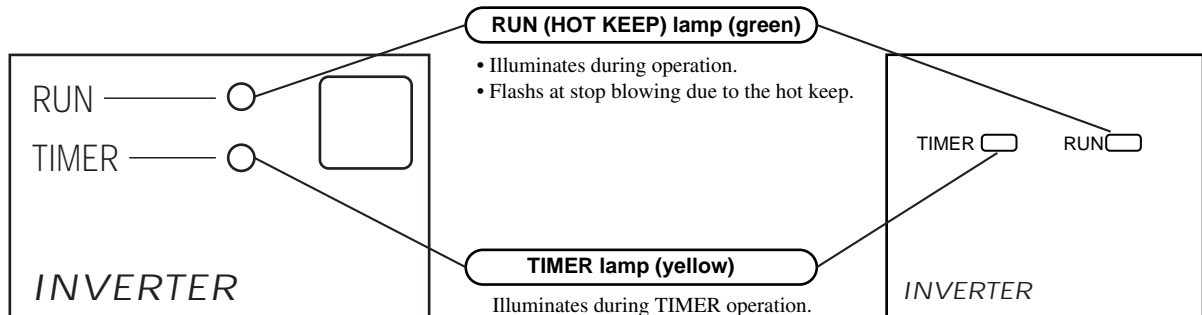

◆ **Air flow and external static pressure characteristics (Heating: Hi)**  
**SRRM40ZA**

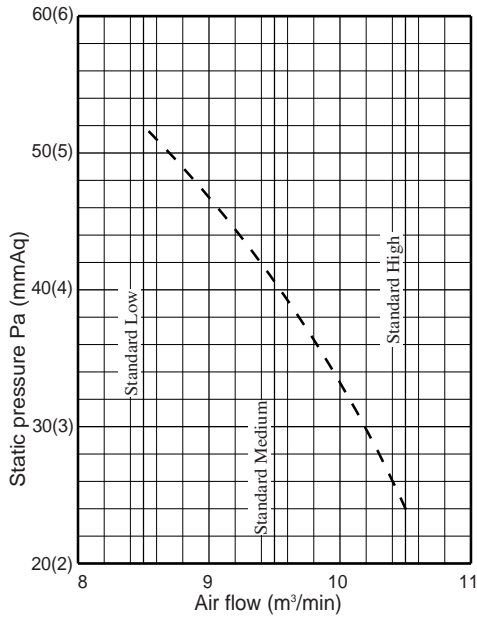

◆ **Air outlet unit air flow and friction loss characteristics**  
 • **Air outlet unit (Part number: RTB12)**  
**(Air outlet chamber + Air outlet panel)**

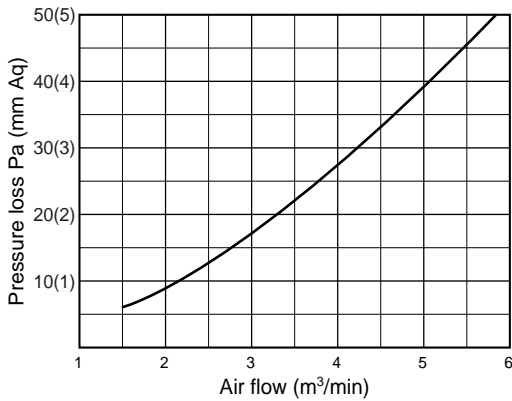

◆ **Air inlet grille air flow and friction loss characteristics**  
**(Part number: RTS12)**

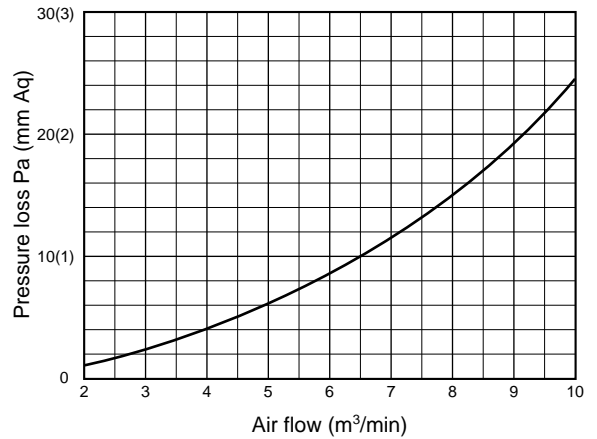

◆ **Flexible duct (ø 150) friction loss characteristics**

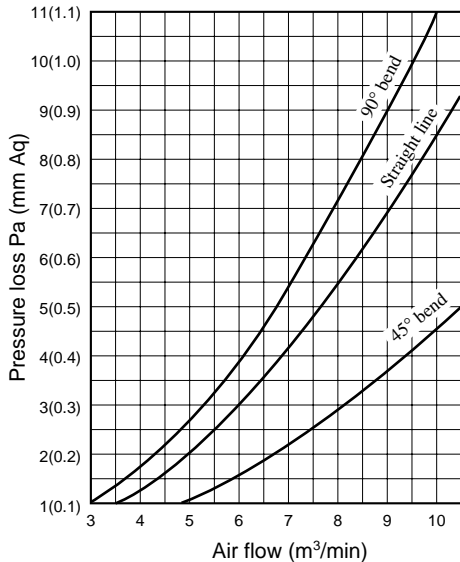

Pressure loss for:  
 Straight line: per 1 meter  
 90° bend: per 1 bend  
 45° bend:

## Selection chart

Correct the cooling capacity in accordance with the conditions as follows. The net cooling capacity can be obtained in the following way.

$$\text{Net capacity} = \text{Capacity shown on specification} \times \text{Correction factors as follows.}$$

### (1) Coefficient of cooling capacity in relation to temperatures

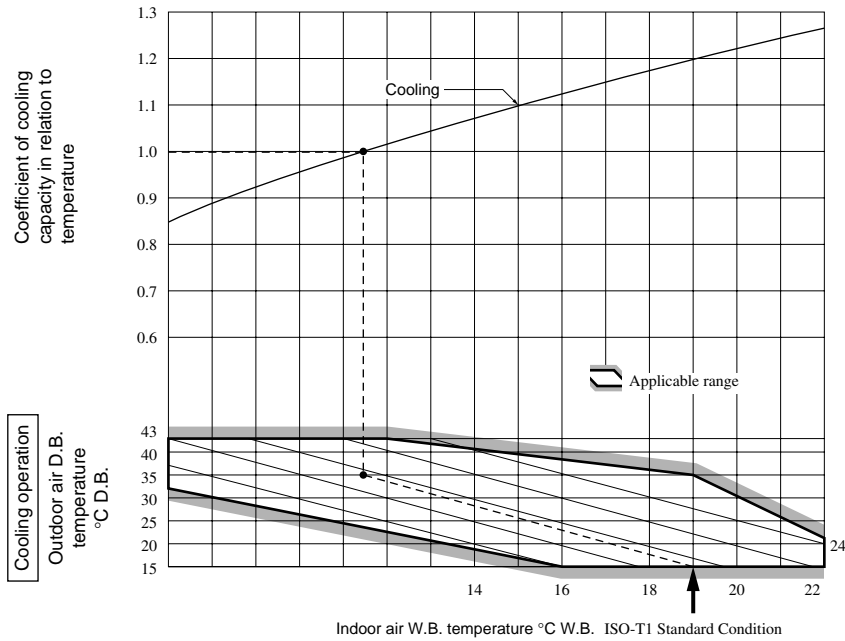

### (2) Correction of cooling capacity in relation to one way length of refrigerant piping

It is necessary to correct the cooling capacity in relation to the one way piping length between the indoor and outdoor units.

Piping length [m]	7	10	15	20	25
Cooling	1.0	0.99	0.975	0.965	0.95